

Edge Analytics Appliance

Operating Instructions

Software Version 4.00

Before operating the unit, please read this manual thoroughly and retain it for future reference.

REA-C1000

Table of Contents

Overview

Using This Manual	4
Precautions Regarding Personal Information	5
Precautions for Preventing Access to the Unit by an Unintended Third Party	5
Features	5
Location and Function of Parts	6
System Configuration	7
Using single HDMI input and output	7
Using two HDMI input and outputs	8
Live streaming using RTMP protocol	9

Installation and Connection

Installing	10
Mounting using mounting screws	10
Connecting	10
Connecting to AC power supply	10

Initial Setup

Setting Up a Computer	11
Accessing the Unit from a Web Browser	11
Screen Structure	12
Configuring Initial Setup Items	12
Enabling option functions	12
Starting applications	13
Checking notifications	13

Unit Setup (Common Settings)

Basic Operations in the Common Settings

Menu	14
Input/Output	14
Video	15
Audio	16
Network	17
Security	18
[User] tab	18
[Access] tab	18
[SSL] tab	19
[Referer] tab	20
Streaming	21
[Streaming] tab	21
[Codec] tab	23
Starting/stopping RTMP streaming	23
Licenses	24
[License] tab	24

[History] tab	25
System	25
[Information] tab	25
[Date & Time] tab	26
[Initialize] tab	26
[Update] tab	27
[EULA] tab	27
[Software] tab	27

Application Setup and Operation

Configuring an Application	28
Common application setup operation	28
Running an application	28
Handwriting Extraction Application	29
Preparation before setup	29
Configuring the Handwriting Extraction application	30
Running the Handwriting Extraction application	33
PTZ Auto Tracking Application	35
Preparation before setup	35
Configuring the PTZ Auto Tracking application	36
Running the PTZ Auto Tracking application	39
Close-up by Gesture Application	41
Preparation before setup	41
Configuring the Close-up by Gesture application	41
Running the Close-up by Gesture application	42
Chroma key-less CG Overlay Application	43
Preparation before setup	43
Configuring the Chroma key-less CG Overlay application	44
Running the Chroma key-less CG Overlay application	45
Real-time Cropping Application	46
Preparation before setup	46
Configuring the Real-time Cropping application	47
Running the Real-time Cropping application	48
Registering a face in the face database	49
Editing the face database	50

Appendix

Message List	51
LED indicators	51
Web browser display	51
Troubleshooting	53
Supported Cameras and Available Camera Functions	54

About Use of GNU GPL/LGPL Software	55
Specifications	55
External dimensions	56

Overview

Safety Regulations (supplied)

Describes the important points for safe use of the unit. Be sure to read it.

Operating Instructions (This document/ Web)

These operating instructions describe the names of the various parts of the unit, and installation, connection, and operation methods.

Using This Manual

The Operating Instructions document is designed to be read on a computer display.

The content you need to know in order to use the unit is described here.

Read it before you operate the unit.

Jumping to a related page

When you read the instructions on a computer display and click on the related part of the relevant page that is being displayed, you jump to the related page. Relevant pages can be searched easily.

Software display examples

The software displays described in this manual are explanatory examples. Note that some displays may be different from the ones that actually appear.

Printing the Operating Instructions

Depending on your system, certain displays or illustrations in the Operating Instructions, when printed out, may differ from those that appear on your screen.

NOTICE TO USERS

© 2018 Sony Corporation.

All rights reserved. This manual or the software described herein, in whole or in part, may not be reproduced, translated or reduced to any machine readable form without prior written approval from Sony Corporation.

SONY CORPORATION PROVIDES NO WARRANTY WITH REGARD TO THIS MANUAL, THE SOFTWARE OR OTHER INFORMATION CONTAINED HEREIN AND HEREBY EXPRESSLY DISCLAIMS ANY IMPLIED WARRANTIES OF MERCHANTABILITY OR FITNESS FOR ANY PARTICULAR PURPOSE WITH REGARD TO THIS MANUAL, THE SOFTWARE OR SUCH OTHER INFORMATION. IN NO EVENT SHALL SONY CORPORATION BE LIABLE FOR ANY INCIDENTAL, CONSEQUENTIAL OR SPECIAL DAMAGES, WHETHER BASED ON TORT, CONTRACT, OR OTHERWISE, ARISING OUT OF OR IN CONNECTION WITH THIS MANUAL, THE SOFTWARE OR OTHER INFORMATION CONTAINED HEREIN OR THE USE THEREOF.

Sony Corporation reserves the right to make any modification to this manual or the information contained herein at any time without notice. The software described herein may also be governed by the terms of a separate user license agreement.

- The terms HDMI and HDMI High-Definition Multimedia Interface, and the HDMI Logo are trademarks or registered trademarks of HDMI Licensing Administrator, Inc. in the United States and other countries.
- Microsoft, Windows, and Internet Explorer are registered trademarks of United States Microsoft Corporation in the United States and/or other countries.
- JavaScript is a trademark or registered trademark of Oracle Corporation, its affiliates or subsidiaries in the United States and other countries.
- Adobe, Adobe Reader and Adobe Flash are trademarks of Adobe Systems Incorporated.
- Google Chrome is a registered trademark of Google Inc.

Other system names, product names appearing in this document are trademarks or registered trademarks of their respective manufacturers. Trademarked items are not indicated by ® or ™ symbols in this document.

Precautions Regarding Personal Information

You can register the face of a person for the face identification function of “Real-time Cropping” in the unit. The registered face recognition information is retained inside the unit. If the unit is accessed by an unintended third party, there is a risk that the registered face information could be viewed.

Precautions for Preventing Access to the Unit by an Unintended Third Party

The unit may be accessible by an unintended third party on the network, depending on the usage environment. Changing the user name and password of the administrator from the default settings is highly recommended for security reasons. For details about changing the user name and password, see “Security” (page 18).

If the unit is accessed by an unintended third party, there may be undesired effects, such as operations or settings that may interfere with operation of the unit or the registered face information could be viewed.

The unit can be fraudulently accessed in a network environment where a device is connected or can be connected to the network without the administrator’s permission, or a computer or other network device connected to the network can be used without any permission. Connect to these environments at your own risk. Also, use the SSL function, Referer check function, or other security measures to prevent unauthorized access to the unit. For details about functions, see “Security” (page 18).

Notes

- The China model does not support the SSL function.
- To protect customer information, reset the settings of this unit to the factory settings when lending or transferring the unit to another person and when disposing of the unit.

Features

The REA-C1000 is a device that analyzes video that is input from a camera, computer, or other device, and automatically generates video content in real-time that previously would have required significant time and human resources, and been expensive to create. REA-C1000 configuration and application operation can be controlled intuitively using a simple screen displayed in a web browser on a computer connected to the network.

The unit features the following applications.

Handwriting Extraction

This application identifies and extracts text and diagrams drawn on a whiteboard or blackboard in real-time, and renders them so that they appear in front of the speaker.

PTZ Auto Tracking

This application tracks a moving target, and automatically moves a remote camera to maintain optimum compositing while shooting.

Note

For details about supported remote cameras, contact your distributor.

Close-up by Gesture

This application interprets specific gestures of people in the video, and automatically zooms in on the corresponding area. You can display two images (a wide angle view and zoomed view) in real-time.

Chroma key-less CG Overlay

This application can generate simple CG composite content in real-time, without requiring a studio with dedicated green or blue screen facilities.

Real-time Cropping

This application simultaneously displays the wide-angle view and a cropped view, from a single camera, by cutting out a desired portion of the main view in real-time, creating the effect of shooting with two cameras. The focus area extraction function includes a “Focus Area Cropping” function that automatically tracks and extracts a specific object, and a “Fixed Area Cropping” function that extracts a specified area. The cropped view, simultaneously output with the main view, can be selected from two configured areas.

Location and Function of Parts

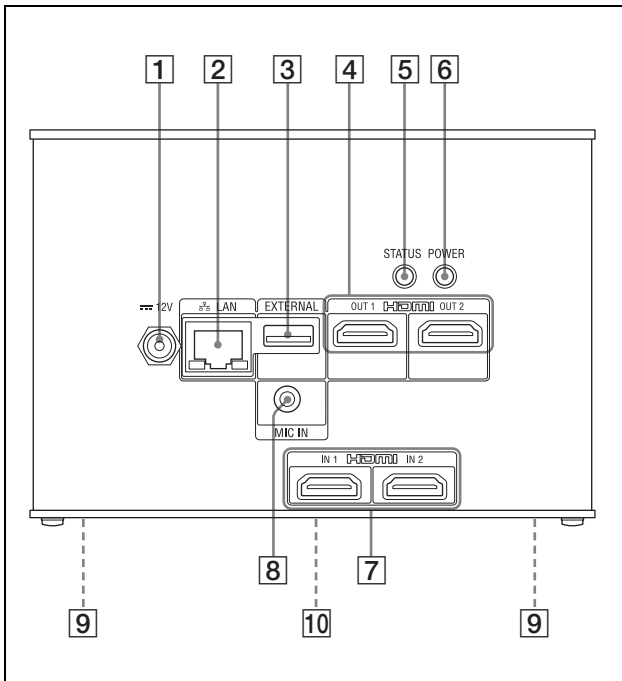

- 1** **12 V (DC power input) connector**
Connect to an AC adapter (not supplied).

Note

For details about supported AC adapters, contact your distributor. Use of other AC adapters may cause a fire or malfunction.

- 2** **LAN (network) connector (RJ-45)**
Connect to a 10BASE-T, 100BASE-TX, or 1000BASE-T switching hub using a LAN cable (not supplied, category 5 or higher, shielded twisted pair).

Notes

- For safety, do not connect the connector for peripheral device wiring that might have excessive voltage to this port. Follow the instructions for this port.
- When connecting this product to a network, connect via a system that provides a protection function, such as a router or firewall. If connected without such protection, security issues may occur.

- 3** **EXTERNAL connector**

Note

Not supported in the current software version.

- 4** **HDMI OUT 1/HDMI OUT 2 connectors**
Connect to the HDMI input connectors of a display, projector, or other video device to display the output video from the unit.

- 5** **STATUS button/LED**
Press and hold the button for 5 seconds with the unit turned so that the POWER LED starts flashing green. Press and hold the POWER button for 3 seconds while the LED is flashing to restart the unit and restore all settings, including network settings, to their factory default settings. Lights in green when the unit is operating normally. Lights in red when not connected to the network. Flashes in red when an error (such as an over-temperature alarm) occurs in the unit.

- 6** **POWER button/LED**
Power is supplied and the POWER LED lights in green when the unit is connected to an outlet using an AC adapter (not supplied) and power cord. To turn the unit off, press and hold the button for 3 seconds. The POWER LED goes out when the unit turns off. To turn the unit on again, press the POWER button. The POWER LED lights in green. In standby state, the power LED lights in orange. For details about switching to standby state, see “[Standby]” (page 26).

- 7** **HDMI IN 1/HDMI IN 2 connectors**
Connect to the HDMI output connectors of a camera, computer, or other video device.

- 8** **MIC IN connector**
Connect to the audio output connector of an audio device.

- 9** **Mounting screw holes (four locations on bottom panel)**
Use to mount the unit. For details, see “Mounting using mounting screws” (page 10).

- 10** **Ratings label (bottom panel)**

Important

This label shows the name of the unit and its electrical ratings.

System Configuration

The unit can be arranged into various system configurations with other devices (not supplied). The diagram below shows a typical system configuration.

Tip

We recommend that you build a 1000BASE-T network if using the streaming function.

Using single HDMI input and output

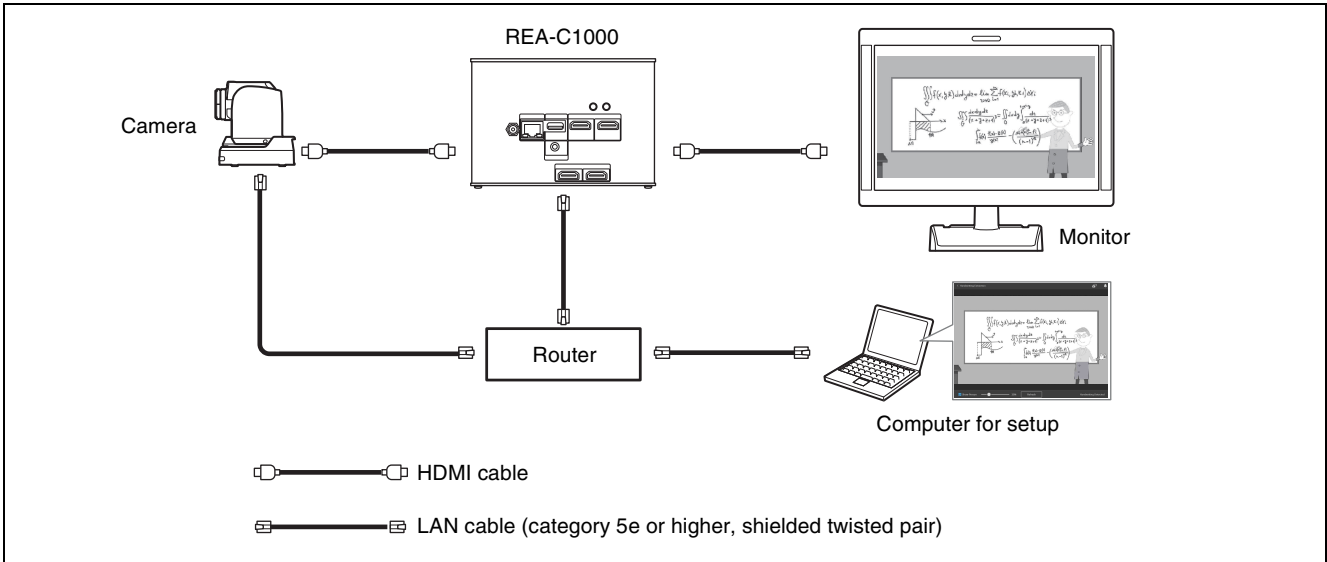

Using two HDMI input and outputs

Using two HDMI inputs and outputs allows simultaneous use of the PTZ Auto Tracking and Handwriting Extraction functions.

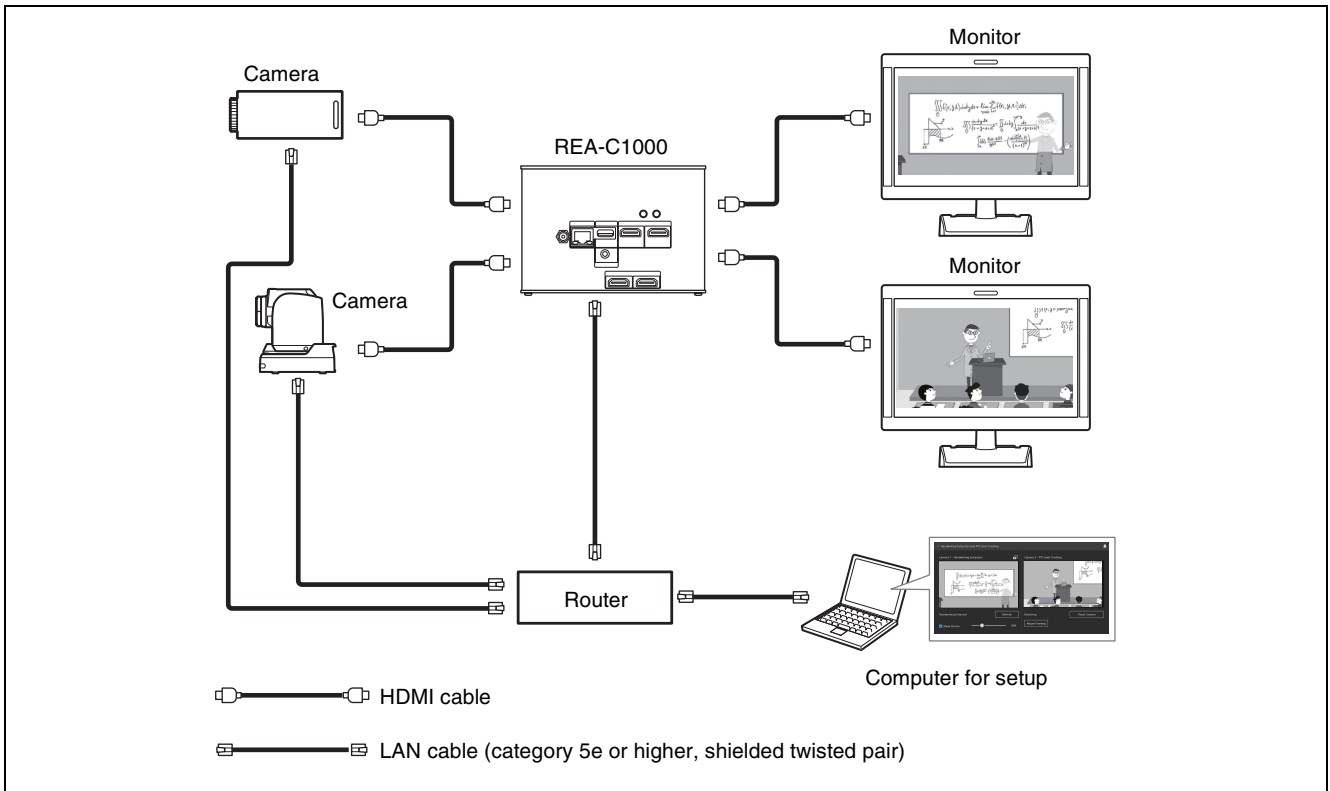

Live streaming using RTMP protocol

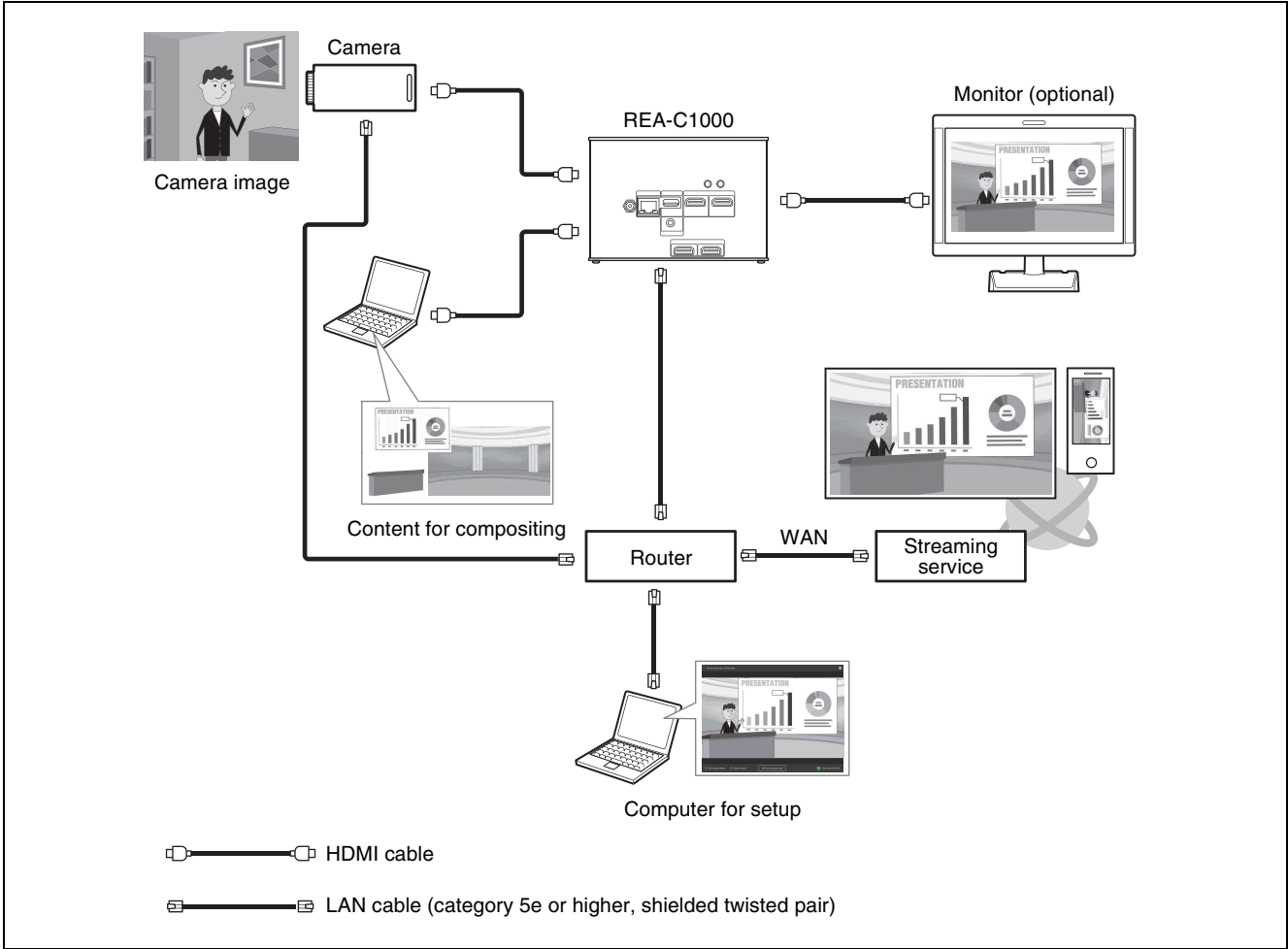

Installing

Install the unit on a level surface, such as a desktop. If, unavoidably, you need to mount the unit on an inclined surface, mount the unit using the mounting screw holes on the bottom panel to prevent the unit from falling.

Notes

- Cables may catch on the connector shell of other cables connected to adjacent connectors and not be connected properly, depending on the cables used. Check that the cables can be used with the unit beforehand.
- Mount the unit so that no strong force is applied to the cables connected to the unit. Cables may be pulled out or the unit may malfunction.
- Notes about temperature rise of the unit
 - The unit may become hot during use. This is not a malfunction.
 - Avoid use where the unit is in direct contact with exposed skin for extended periods.
 - The temperature rise may occur quickly in high-temperature environments.

Mounting using mounting screws

Attach the unit using the four mounting holes (for M3 screws) on the bottom panel. Use M3 screws that meet the following criteria. Attach the unit with the screws against a flat surface, without ridges or undulations, and tighten securely.

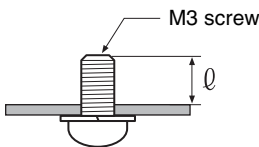

$\ell = 3 \text{ mm to } 8 \text{ mm}$

Connecting

Connecting to AC power supply

Connect to the AC power supply using an AC adapter (not supplied) and power cord. The POWER LED lights green when power is supplied. After the unit has powered up, the STATUS LED lights green when access from a web browser becomes enabled.

Notes

- For details about supported AC adapters (not supplied), contact your distributor. Use of other AC adapters may cause a fire or malfunction.
- Connect the power supply to the unit only after powering on the other peripheral devices.

Initial Setup

Perform the following configuration when starting the unit for the first time. This configuration is performed by the administrator.

Setting Up a Computer

Prepare a computer and connect it to the network. The recommended operating environment is given below.

OS: Windows 10 Pro (32-bit version/64-bit version)

Web browser: Google Chrome Ver. 85 or later

Notes

- Turn off tablet mode.
- Do not use the Back button of the browser.
- JavaScript is used for the web page display when accessing the unit. The web page may not display correctly if your computer uses certain software, such as anti-virus software.

Accessing the Unit from a Web Browser

Perform the following configuration to enable access of the unit from a web browser.

1 Assign an IP address to the unit using RM-IP Setup Tool.

The IP address of the unit is obtained automatically using DHCP, but you can change it using RM-IP Setup Tool if required.

For details about setting the IP address, refer to the RM-IP Setup Tool guide.

Tip

Download RM-IP Setup Tool and the RM-IP Setup Tool guide separately from the following website.
www.sony.net/CameraSystem

2 Check the IP address of the unit.

You can check the IP address using RM-IP Setup Tool.

For details about checking the IP address, refer to the RM-IP Setup Tool guide.

3 Start a web browser on the computer, and enter the IP address of the unit in the address bar.

4 Access the unit.

User name and password authentication is required to access the unit. The user name and factory-set password of the unit are given below.

User name: admin

Password: Admin_1234

Tip

In RM-IP Setup Tool, the unit is detected on the “Camera” tab. You can check and set the name and IP address of the unit from RM-IP Setup Tool in the same way as for a remote camera. By default, “Device0” is displayed as the name of the unit.

Screen Structure

The following screen appears in the web browser when you access the unit.

You can configure the unit, and configure and run applications from this screen.

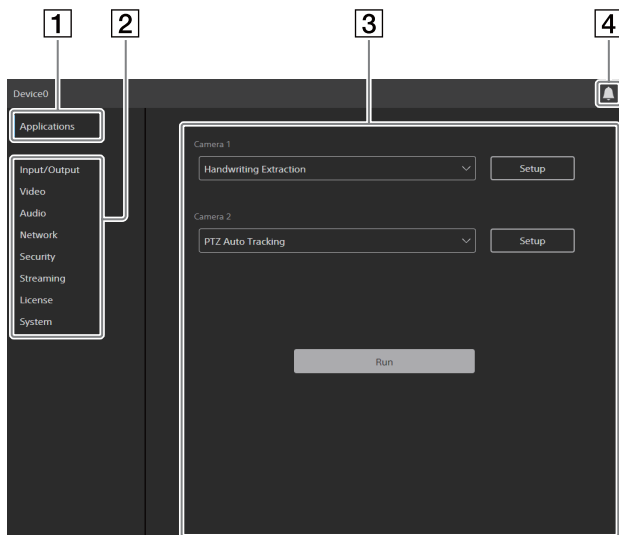

Note

The initial setup screen appears by default when you access the unit in its factory default state.

1 [Applications]

Click to select, configure, or run an application. Clicking displays the available applications.

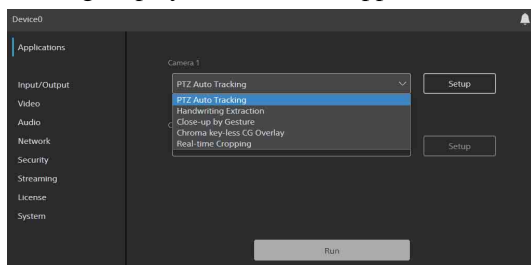

Selecting an application displays the setup and run screen of the application.

For details about selecting, configuring, and running applications, see “Application Setup and Operation” (page 28).

2 Common settings menu

Click to configure common settings of the unit, such as video and network settings.

3 Operation/settings area

Displays the selected menu item screen or application setup screen.

4 Notifications button

A red indicator is displayed on the notifications button when there is a notification relating to the status of the unit. Click it to display the notifications dialog.

Configuring Initial Setup Items

Access the unit in the factory default state, and configure the following items.

[EULA]

Displays the EULA (End User License Agreement).

[Language]

Specify the display language of the screen. For details about configuration, see “System” (page 25).

[Administrator]

Set [User Name] and [Password] for the administrator. For details about configuration, see “Security” (page 18).

[Network]

Configure the network settings for connection between the unit and a computer. For details about configuration, see “Network” (page 17).

[Date & Time]

Set the date and time on the unit. For details about configuration, see “System” (page 25).

[System Frequency]

Set the system frequency for the unit to support. For details about configuration, see “Video” (page 15).

Notes

- Be sure to change the default user name and password used when you first start the unit. After changing the user name and password, reauthentication using the new user name and password is required.
- If the network settings are changed, access the unit again using the changed network information.
- The unit must be restarted after completing the initial setup.

Enabling option functions

Option functions must be enabled before configuring or running an application. To enable an option function, you must activate a pre-installed license or purchase and install a license. For details about installing a license, see “Licenses” (page 24).

Licenses

The following option function licenses are available for the unit.

- Handwriting Extraction license
Enables the Handwriting Extraction function.
REA-L0100: Permanent license
REA-L0106: Period license (180 days)
REA-L0112: Period license (365 days)
- PTZ Auto Tracking license
Enables the PTZ Auto Tracking function.
REA-L0200: Permanent license
- Close-up by Gesture license
Enables the Close-up by Gesture function.
REA-L0300: Permanent license
REA-L0306: Period license (180 days)
REA-L0312: Period license (365 days)
- Chroma key-less CG Overlay license
Enables the Chroma key-less CG Overlay function.
REA-L0400: Permanent license
REA-L0401: Period license (30 days)
REA-L0403: Period license (90 days)
REA-L0412: Period license (365 days)
- Focus Area Cropping license
Enables the Focus Area Cropping function.
REA-L0500: Permanent license
REA-L0501: Period license (30 days)
REA-L0503: Period license (90 days)
REA-L0512: Period license (365 days)

Pre-installed licenses

You can trial test option functions by activating pre-installed licenses on the unit, without having to purchase and install any licenses.

For details about activation, see “Licenses” (page 24).

Notes

- Activating pre-installed licenses enables you to trial test option functions for a limited time only. However, if a period license is installed for the same function as a trial license which has not been activated, that trial license becomes disabled.
- For details about purchasing licenses, contact your distributor.

Starting applications

Access the unit from a web browser to select and run an application.

A license may need to be enabled to run an application.

For details about configuring applications, see “Application Setup and Operation” (page 28).

Tip

If the unit is turned off normally while an application is running, the application will automatically restart the next time the unit is turned on.

Checking notifications

You can check the status of the unit and the status of connections with external devices in the notifications dialog.

The notifications dialog is displayed automatically when the status of the unit changes. You can also display the dialog by clicking the notifications button at the top right of the screen.

For details about notifications, see “Message List” (page 51).

Unit Setup (Common Settings)

This section describes the common settings of the unit on each menu page. This configuration is performed by the administrator.

Basic Operations in the Common Settings Menu

Click an item in the common settings menu on the left side of the screen to display the setup screen for that item.

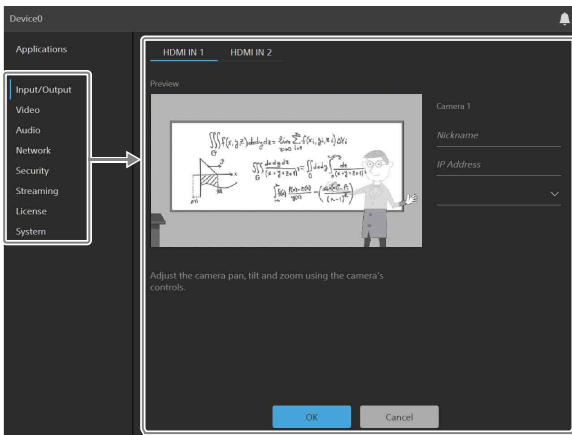

If the setup screen displays multiple tabs, click on a tab to switch the display in the setup screen.

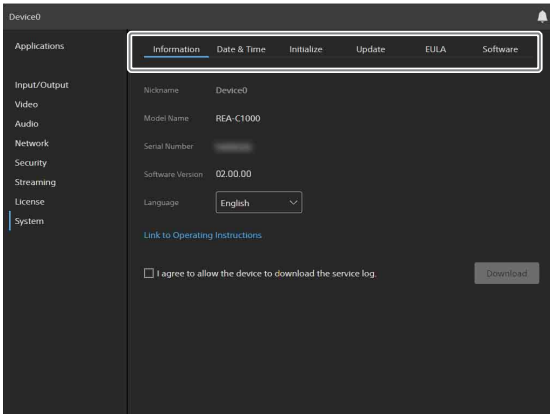

The following buttons at the bottom of the setup screen are common for all items.



[OK]: Click to apply the settings. The settings are not applied on the unit until you click this button.
[Cancel]: Click to discard the settings and return to the previous state.

Note
Only those items that are currently configurable are displayed. Items that are grayed out cannot be configured. Functions that are not installed are not displayed.

Input/Output

Use to configure the connected camera that supplies the video input of the unit.

You can preview and adjust the video from a camera or device connected to the HDMI IN 1 connector or HDMI IN 2 connector.

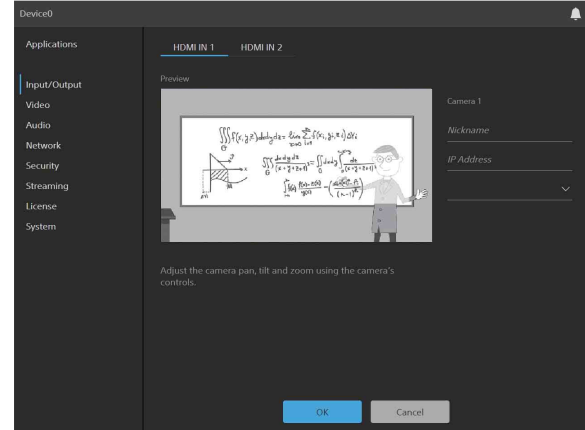

[HDMI IN 1] / [HDMI IN 2]

Select the connector to which the camera or device whose video you want to preview is connected.

Preview image

When a camera or other video device connected to the HDMI IN 1 connector or HDMI IN 2 connector is operating normally, a preview of the image from the camera or device is displayed.

[Nickname]

Enter a nickname for the connected camera or device. This is used as an identifier when configuring applications.

[IP Address]

Enter the IP address of the remote camera to control a Sony remote camera from the unit using VISCA over IP. To clear the IP address, enter "0.0.0.0".

[Model Name]

Select the model name or enter an arbitrary model name for the remote camera to control from the unit using VISCA over IP.

Note

When a supported camera is connected, the following camera functions can be controlled by the unit. For correct camera operation, configure the [IP Address] and [Model Name] settings.

- Pan, tilt, and zoom functions
 - Control using PTZ Auto Tracking application
- Exposure and white balance functions
 - Control using Handwriting Extraction application
- Tally lamp function
 - Control using PTZ Auto Tracking application
 - Control using Real-time Cropping application

For details about supported cameras and their available camera functions, see “Supported Cameras and Available Camera Functions” (page 54).

To use the PTZ Auto Tracking application, be sure to connect a camera that supports pan, tilt, and zoom functions.

Video

Use to configure the system frequency and output video of the unit.

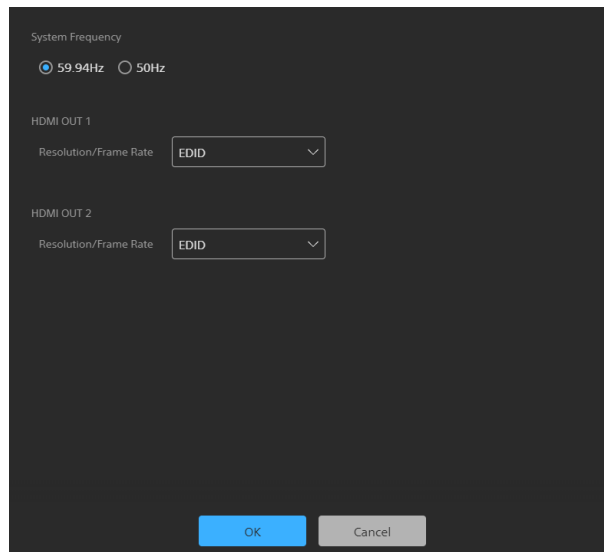

[System Frequency]

Select the system frequency.

[59.94Hz]: Supports input and output video in 59.94 Hz systems.

[50Hz]: Supports input and output video in 50 Hz systems.

HDMI OUT 1

Set the output image size and frame rate of the video output from the HDMI OUT 1 connector.

[EDID]: Automatically determine and output a video image that is compatible with the connected output device.

[3840×2160 / 29.97P]: Output at 3840×2160 29.97P. (Available only when the system frequency is 59.94 Hz)

[3840×2160 / 25P]: Output at 3840×2160 25P. (Available only when the system frequency is 50 Hz)

[1920×1080 / 59.94P]: Output at 1920×1080 59.94P. (Available only when the system frequency is 59.94 Hz)

[1920×1080 / 50P]: Output at 1920×1080 50P. (Available only when the system frequency is 50 Hz)

HDMI OUT 2

Set the output image size and frame rate of the video output from the HDMI OUT 2 connector.

[EDID]: Automatically determine and output a video image that is compatible with the connected output device.

[1920×1080 / 59.94P]: Output at 1920×1080 59.94P. (Available only when the system frequency is 59.94 Hz)

[1920×1080 / 50P]: Output at 1920×1080 50P. (Available only when the system frequency is 50 Hz)

Note

If the system frequency is changed, you must restart the unit.

Audio

Use to configure the audio of the unit.

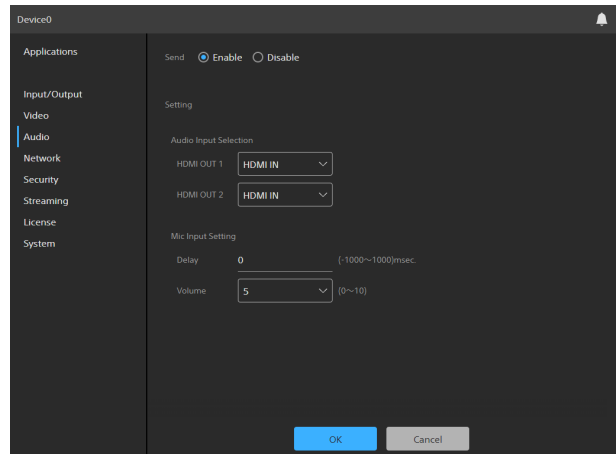
**To enable the audio function**

Select [Enable] in [Send]. The following items can be configured when the audio function is enabled.

[Audio Input Selection]

Select the audio data ([HDMI IN] or [MIC IN]) that is output on [HDMI OUT 1] and [HDMI OUT 2].

[HDMI IN]: Use the audio data that is input on the HDMI IN connector.

[MIC IN]: Use the audio data that is input on the MIC IN connector.

[Mic Input Setting]

Set the audio data that is input from the microphone connected to the MIC IN connector.

[Delay]: Set the audio delay so that the audio data input from the microphone is synced with the video data that is input from HDMI IN.

[Volume]: Set the volume.

Network

Use to configure the network settings for connection between the unit and a computer.

The screenshot shows a network configuration window with the following fields and options:

- MAC Address: [Field]
- Ethernet Status: 1000full
- HTTP Port Number: 80
- HTTPS Port Number: 443
- Obtain an IP address automatically (DHCP)
- IP Address: [Field]
- Subnet Mask: 255.255.255.0
- Default Gateway: [Field]
- Obtain IPv6 address automatically
- IPv6 Address 1: [Field]
- IPv6 Address 2: [Field]
- Link-Local IP Address: [Field]
- Prefix Length: [Field]
- IPv6 Default Gateway: [Field]
- Obtain DNS server address automatically
- Primary DNS Server: [Field]
- Secondary DNS Server: 0.0.0.0

Buttons: OK, Cancel

[MAC Address]: Displays the MAC address of the unit.

[Ethernet Status]: Displays the current communications speed.

[HTTP Port Number]: Displays the port number for HTTP.

[HTTPS Port Number]: Displays the port number for HTTPS.

Note

The China model does not support the SSL function.

To obtain an IP address (IPv4) automatically from a DHCP server

Place a check mark in [Obtain an IP address automatically (DHCP)] to automatically acquire the IP address, subnet mask, and default gateway.

[IP Address]: Displays the current IP address.

[Subnet Mask]: Displays the current subnet mask value.

[Default Gateway]: Displays the current default gateway.

Note

If you select [Obtain an IP address automatically (DHCP)], check that a DHCP server is operating on the network.

To specify a fixed IP address (IPv4)

Clear the [Obtain an IP address automatically (DHCP)] checkbox and enter the following items.

[IP Address]: Enter the IP address of the unit.

[Subnet Mask]: Enter the subnet mask value.

[Default Gateway]: Enter the default gateway.

To obtain an IP address (IPv6) automatically

Place a check mark in [Obtain IPv6 address automatically] to automatically acquire the IP address, prefix length, and default gateway.

[IPv6 Address 1] / [IPv6 Address 2]: Displays the current IPv6 addresses.

[Link-Local IP Address]: Displays the current IPv6 link-local IP address.

[Prefix Length]: Displays the current prefix length.

[IPv6 Default Gateway]: Displays the current IPv6 default gateway.

Notes

- If you select [Obtain IPv6 address automatically], check with the network administrator whether IPv6 assignment is supported.
- Operation in a multi-prefix environment is not supported, and communication may not operate correctly.

To specify a fixed IP address (IPv6)

Clear the [Obtain IPv6 address automatically] checkbox and enter the following items.

[IPv6 Address 1]: Enter the IP address of the unit.

[Prefix Length]: Enter the prefix length.

[IPv6 Default Gateway]: Enter the default gateway.

To obtain the DNS server address automatically

Place a check mark in [Obtain DNS server address automatically] to automatically acquire the addresses of the primary DNS server and secondary DNS server.

[Primary DNS Server]: Displays the current primary DNS server IP address.

[Secondary DNS Server]: Displays the current secondary DNS server IP address.

Note

To obtain the DNS server address automatically, either [Obtain an IP address automatically (DHCP)] or [Obtain IPv6 address automatically] must be enabled. Check with the network administrator whether the environment supports a server address being obtained automatically.

To specify the DNS server address manually

Clear the [Obtain DNS server address automatically] checkbox and enter the following items.

[Primary DNS Server]: Enter the IP address of the primary DNS server.

[Secondary DNS Server]: Enter the IP address of the secondary DNS server.

Security

Use to configure settings relating to security on the unit. The screen consists of [User], [Access], [SSL], and [Referer] tabs.

[User] tab

Use to configure users. You can configure the user name, password, and user access permissions of one administrator and nine general users.

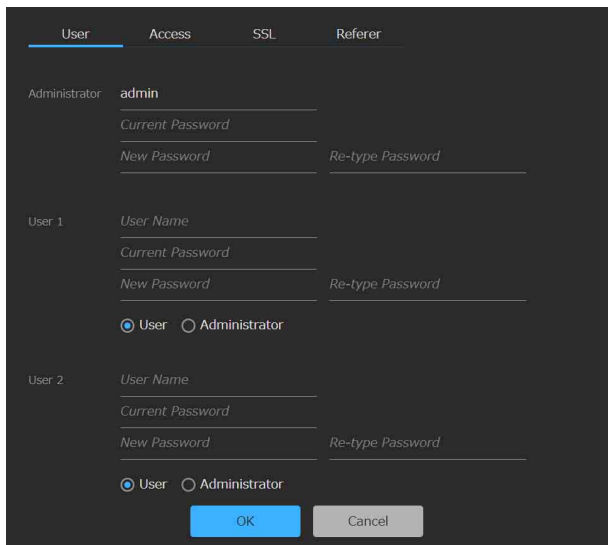

Administrator and general users

Users on the unit are categorized into administrator and general users.

The administrator can access all functions of the unit, including configuration of the unit and applications. A general user has permission to monitor running applications only.

[Administrator], [User 1] to [User 9]

Set the following items for the administrator and each general user.

[User Name]: Enter a user name comprising 5 to 16 characters.

[Current Password]: Enter the currently configured password comprising 8 to 64 characters.

[New Password]: Enter the new password you want to set comprising 8 to 64 characters.

[Re-type Password]: Re-enter the new password you want to set to verify the password.

Administrator permission selection: To grant administrator access to a user, select [Administrator]. To set a general user without administrator access, select [User].

Notes

- The following characters are valid in user names and passwords. Include at least one upper-case letter, one lower-case letter, and one number in passwords.
 - Alphanumeric characters
 - Symbols (!\$%'()=-~^!@`[{}]_/?<>+*.)
- A user name and new password must be configured when adding a user.
- To change the user information, all items must be specified again.
- When deleting a user, leave all fields other than [Current Password] blank.

[Access] tab

Use to configure the security function to restrict the computers that can access the unit.

Similarly, you can also configure security for each network when using IPv6.

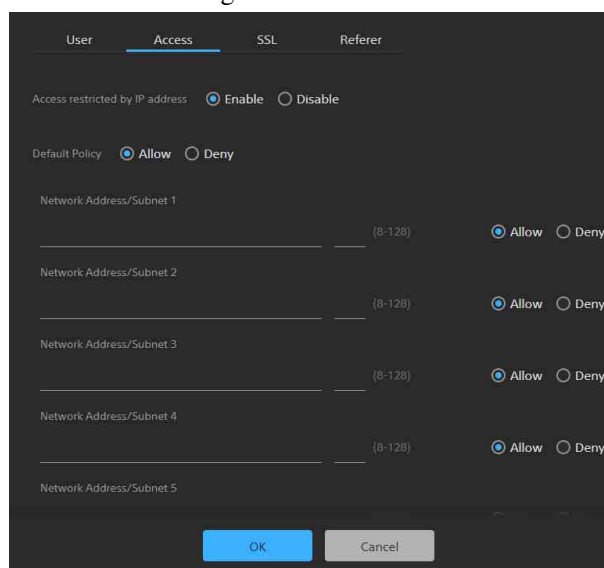

To enable IP address restrictions

Select [Enable] for [Access restricted by IP address], and configure the following items.

[Default Policy]

Select [Allow] or [Deny] to allow or deny access from computers whose network address is outside the ranges configured in [Network Address/Subnet 1] to [Network Address/Subnet 10].

[Network Address/Subnet 1] to [Network Address/Subnet 10]

Enter the network address/subnet mask value that you want to allow or deny access.

You can specify up to ten network addresses and subnet mask values.

Enter a subnet mask value of 8 to 32 (8 to 128 for IPv6). Set access to [Allow] or [Deny] individually for each network address/subnet mask.

Tips

- The subnet mask value indicates the number of bits that are masked off from the left. For example, the subnet mask value for 255.255.255.0 is 24. If you set “192.168.0.0/24” and [Allow], computers having an IP address between 192.168.0.0 and 192.168.0.255 have access allowed.
- You can access the unit even from a computer with an IP address whose access right is set to [Deny], if you enter the user name and password set for the Administrator using the [User] tab of the [Security] page on the authentication screen.

[SSL] tab

Use to configure the SSL or TLS function (hereinafter referred to as SSL). Configuring these settings allows the unit to use SSL communication with client devices.

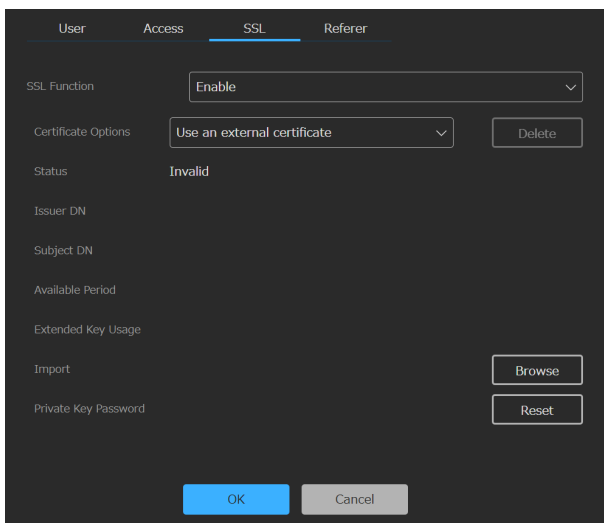

Notes

- The China model does not support the SSL function.
- When using the SSL function, always configure the settings after setting the date and time of the unit. If the date and time are not set correctly, it may not be possible to connect to the unit using a web browser.
- Reload the web browser after you change the SSL settings.
- Software version 2.00 and later employs “TLS1.2” encryption for high-security communication.

To enable the SSL function

Select [Enable] from the [SSL Function] pull-down menu to enable the SSL function.

When [Enable (Allow HTTP connection for some clients)] is selected, both SSL connections and HTTP connections are allowed.

When [Enable] is selected, only SSL connections are allowed.

Precautions with SSL connections

When you use only SSL connections with the SSL function set to [Enable], you will not be able to access the unit if the SSL function is not working properly.

In this case, you must reset the unit to the factory settings. (All settings will be initialized.) To avoid this, check that SSL connection can be established before configuration by performing the following steps.

1 Set the SSL function to [Enable (Allow HTTP connection for some clients)].

Note

Always select [Enable (Allow HTTP connection for some clients)]. If it is not selected and the SSL connection fails, you will not be able to access the unit.

2 Click the [OK] button to close the web browser.

3 Display the web browser using an SSL connection.

4 After confirming that SSL connection is possible, set the SSL function to [Enable].

Tip

If the SSL connection fails while checking the connection, you can select [Enable (Allow HTTP connection for some clients)] to connect using an HTTP connection. Check the settings on the [SSL] tab using an HTTP connection, and then check the SSL connection again.

[Certificate Options]

Select the certificate installation mode.

[Use an external certificate]: This mode uses a certificate (including private key information) issued by a CA. PKCS#12 and PEM certificate formats are supported.

[Use a self-signed certificate (For test use)]: This mode uses a certificate and private key pair generated as described in “To generate a self-signed certificate” (page 20). The private key information corresponding to the certificate is stored within the unit.

You do not need to install an external certificate, but validating its existence, which is one of the SSL functions, is not possible for the following reasons.

- Self-signing uses the private key generated in the unit.
- A preconfigured value is set for the Distinguished Name (Common Name, and so on).
- The certificate is not issued by a CA trusted by the customer’s system.

For reasons of security, we recommend using this certificate only when there is no problem and a lack of total security is not a concern, such as for testing.

Notes

- When [Use a self-signed certificate (For test use)] is selected, a security alert appears when initiating an SSL connection with a web browser.

- SSL connection may not be possible depending on the type of certificate installed in the unit.

To import a certificate

Click the [Browse] button at the bottom right of the setup screen and select the certificate. Click the [OK] button in the file selection dialog to import the selected file into the unit.

Notes

- The import process is invalid if the selected file is not a certificate or if the format of the imported certificate is not allowed.
- In software version 2.00 and later, the following insecure certificates are disabled.
 - Certificates with a private key of 1024 bits or smaller
 - Certificates that use a weak algorithm, such as MD5/SHA1

To generate a self-signed certificate

A self-signed certificate must be generated when [Use a self-signed certificate (For test use)] is selected in [Certificate Options].

Click the [Generate] button to generate a self-signed certificate in the unit.

Clicking the [Generate] button again after generating a self-signed certificate will update the self-signed certificate stored in the unit.

Notes

- Make sure to set the date and time on the unit before performing this operation. If the date and time are not set correctly, it may not be possible to connect to the unit using a web browser.
- Before clicking the [Generate] button to generate a self-signed certificate, select [Use a self-signed certificate (For test use)] in [Certificate Options] and click the [OK] button.

To display the certificate contents

When the certificate has been configured in the unit correctly, information from the certificate appears in [Status], [Issuer DN], [Subject DN], [Available Period], and [Extended Key Usage].

[Status]

Displays whether the status of the certificate is valid or invalid. The following status types are displayed.

[Valid]: The certificate is correctly stored and configured.

[Invalid]: The certificate is not correctly stored and configured. If invalid, possible causes are as follows:

- [Use an external certificate] is selected but the private key password included in the certificate is not specified correctly.
- [Use an external certificate] is selected but the private key included in the certificate is not encrypted. Or the private key password is specified but is not encrypted.

- [Use an external certificate] is selected but the required private key is not included in the certificate.
- [Use a self-signed certificate (For test use)] is selected but a self-signed certificate has not been generated.

Note

When the certificate to be imported is in PKCS#12 format and the private key password is not specified correctly, “<Put correct private key password>” is displayed in the [Issuer DN], [Subject DN], [Available Period], and [Extended Key Usage] fields. Specify the correct private key password.

To delete the imported certificate or self-signed certificate

Click the [Delete] button on the setup screen to delete the imported certificate or self-signed certificate.

To specify the private key password

Enter a password comprising up to 50 characters for the private key included in the certificate in [Private Key Password]. Entry is supported only when [Certificate Options] is set to [Use an external certificate].

Leave the field for this parameter blank if the private key included in the certificate is not encrypted.

To enter the private key password, click the [Reset] button and enter a password.

Note

Click the [Cancel] button at the bottom of the screen if you want to cancel changing the private key password after clicking the [Reset] button. Note that clicking the [Cancel] button also restores all other setting items on the [SSL] tab to the previous settings.

[Referer] tab

Use the [Referer] tab to configure the Referer check function. “Referer Check” is a function that checks whether the web page which requested the access is legitimate when the unit is accessed from an external source. If the web page cannot be confirmed as legitimate, access is denied.

If you want to access the unit from a web page other than one that the unit provides, register the host name and port number that hosts the web page on this tab.

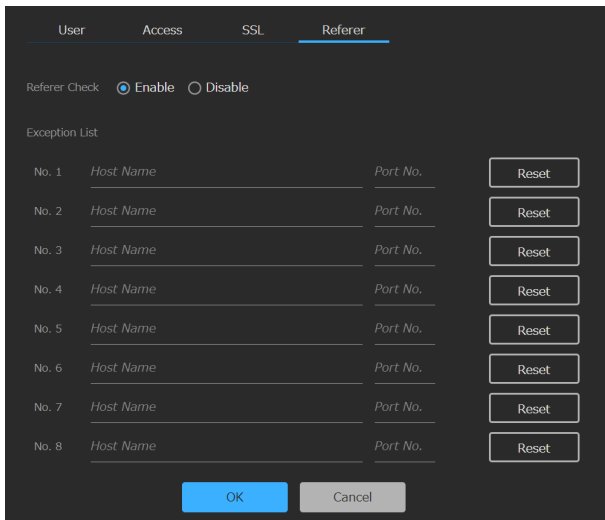

To enable Referer check

Select [Enable] in [Referer Check]. The following items can be configured when Referer check is enabled.

[No. 1] to [No. 10]: Register hosts that are not subjected to the Referer check as an exception list.

[Host Name]: Enter the host name or IP address of the computer that hosts the web page you want to register in the exception list.

[Port No.]: Enter the port number of the computer that hosts the web page you want to register in the exception list.

[Reset]: Reset the exceptions settings.

Streaming

Use to configure streaming.

The screen consists of [Streaming] and [Codec] tabs.

Note

Streaming using the RTMP protocol and RTSP protocol employed by the unit is susceptible to the possibility that streaming data can be accessed by a third party during streaming. To ensure the confidentiality of the streamed data, it is recommended that you connect the unit and streaming data receiver within a closed network or consult an organization with specialized knowledge.

[Streaming] tab

The unit supports streaming using the RTMP/RTMPS protocol and RTSP protocol. Use the [Streaming] tab to select the protocol and configure settings related to streaming.

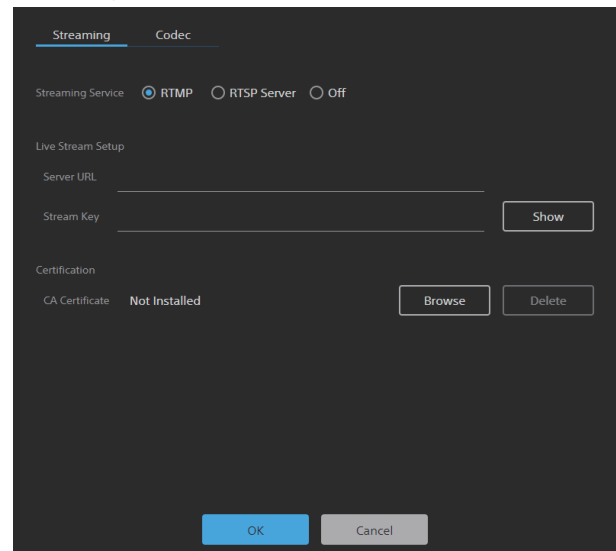

To enable streaming

Select the protocol to use in [Streaming Service].

When [RTMP] is selected, you can start and stop streaming from the run screen of the application.

When [RTSP Server] is selected, launching the application enables the streaming function.

[RTMP]: Select the RTMP/RTMPS protocol.

[RTSP Server]: Select the RTSP protocol.

[Off]: Disable the streaming function.

Configuration items when [RTMP] is selected in [Streaming Service]

The screenshot shows the 'Streaming' tab with 'RTMP' selected under 'Streaming Service'. The 'Live Stream Setup' section includes fields for 'Server URL' and 'Stream Key', with a 'Show' button next to the Stream Key field. The 'Certification' section shows 'CA Certificate' as 'Not Installed' with 'Browse' and 'Delete' buttons. 'OK' and 'Cancel' buttons are at the bottom.

[Server URL]

Set the URL of the upload destination server. Specify a character string starting with “rtmp://” or “rtmps://”.

[Stream Key]

Enter the stream key obtained from the site being used. Click the [Show] button to display the entered characters.

Note

Exercise caution when handling the stream key. There is a risk of stream spoofing if the stream key is revealed to a third party.

[CA Certificate]

Install the CA certificate required for streaming using the RTMPS protocol.

Click the [Browse] button and select the CA certificate to install. Click the [OK] button in the file selection dialog to install the selected file into the unit. If a CA certificate is already installed in the unit, it is updated. Click the [Delete] button on the setup screen to delete the installed certificate.

Notes

- Install the CA certificate required for the streaming service.
- The China model does not support the RTMPS protocol. Accordingly, the certificate installation function is not available.

Configuration items when [RTSP Server] is selected in [Streaming Service]

The screenshot shows the 'Streaming' tab with 'RTSP Server' selected under 'Streaming Service'. The 'Unicast Streaming' section includes fields for 'RTSP Video Port Number 1' (51000), 'RTSP Audio Port Number 1' (57000), 'RTSP Video Port Number 2' (53000), and 'RTSP Audio Port Number 2' (58000). The 'RTSP Setting' section includes 'RTSP Authentication' (On), 'RTSP Port Number' (554), and 'RTSP Timeout (sec.)' (60). 'OK' and 'Cancel' buttons are at the bottom.

[Unicast Streaming]

Set the H.264 video data and AAC audio data communication port number for each port.

Note

Specify a different number for the video port number and audio port number.

[RTSP Video Port Number 1], [RTSP Video Port Number 2]: Specify the H.264 video data communication port number for RTSP unicast streaming. Specify an even number in the range 1024 to 65534. The default settings are 51000 and 53000. The odd-numbered ports obtained by incrementing the ports specified here are used for data communication and control of the video. In addition, when there are multiple simultaneous sessions, different port numbers are used for each session starting from the number specified here. The [Streaming Output 1] and [Streaming Output 2] settings on the [Codec] tab correspond to [RTSP Video Port Number 1] and [RTSP Video Port Number 2], respectively.

[RTSP Audio Port Number 1], [RTSP Audio Port Number 2]: Specify the AAC audio data communication port number for RTSP unicast streaming. Specify an even number in the range 1024 to 65534. The default settings are 57000 and 58000. The odd-numbered ports obtained by incrementing the ports specified here are used for data communication and control of the audio. In addition, when there are multiple simultaneous sessions, different port numbers are used for each session starting from the number specified here. The [Streaming Output 1] and [Streaming Output 2] settings on the [Codec] tab correspond to [RTSP Audio Port Number 1] and [RTSP Audio Port Number 2], respectively.

[RTSP Setting]: Configure the RTSP settings not included in [Unicast Streaming].

[RTSP Authentication]

Set whether to use RTSP authentication as the user authentication.

[RTSP Port Number]: Set the port number to use for RTSP streaming. The default setting is 554. The RTSP server reboots when the setting is changed.

[RTSP Timeout]: Specify the timeout value for a Keep-Alive request in an RTSP session. You can specify a timeout value in the range 0 seconds to 600 seconds. When 0 seconds is specified, a timeout does not occur for a Keep-Alive request.

[Codec] tab

Use the [Codec] tab to configure settings relating to codecs. The codec settings are common to both the RTMP/RTMPS protocol and RTSP protocol.

When [RTMP] is selected in [Streaming Service], only images processed by the application can be streamed. Accordingly, [Streaming Output 2] cannot be configured. Set [Streaming Output 1] to [HDMI OUT 1] or [HDMI OUT 2], according to the application being used.

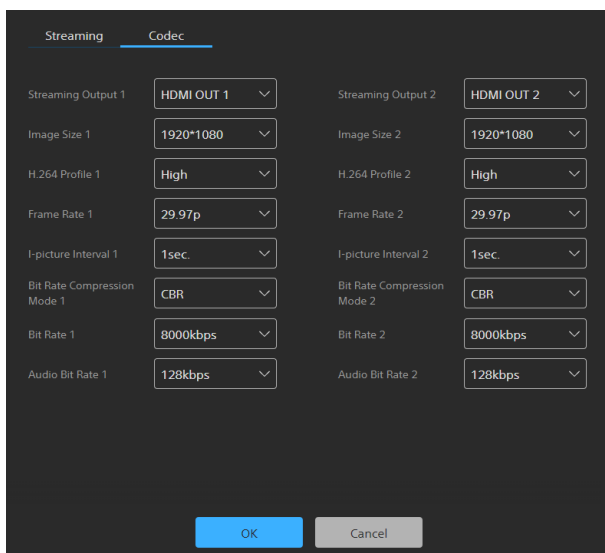

[Streaming Output 1], [Streaming Output 2]: Select the content ([HDMI OUT 1] or [HDMI OUT 2]) for the streaming output.

[Image Size 1], [Image Size 2]: Select the image size to stream from the camera.

[H.264 Profile 1], [H.264 Profile 2]: Select the H.264 codec video profile ([High], [Main], or [Baseline]). The video compression efficiency increases in the order [High], [Main], and [Baseline]. Certain profile methods may not be handled correctly, depending on your system. Select the method used by your system.

[Frame Rate 1], [Frame Rate 2]: Specify the video frame rate. The value indicates the number of frames streamed per second (fps).

[I-picture Interval 1], [I-picture Interval 2]: Set the I-picture insertion interval in seconds.

[Bit Rate Compression Mode 1], [Bit Rate Compression Mode 2]: Set to CBR (fixed) in the current software version, and cannot be modified.

[Bit Rate 1], [Bit Rate 2]: You can set the bit rate for each video streaming line. High-quality video streaming is supported by setting the bit rate to a high value.

[Audio Bit Rate 1], [Audio Bit Rate 2]: To place emphasis on data capacity, select [128kbps]. To place emphasis on audio quality, select [256kbps]. This setting has no effect on the audio signal embedded in the HDMI output.

Note

For the RTMP/RTMPS protocol, configure each setting on the [Codec] tab using the recommended values for the site being used. Communication bandwidth restrictions may occur, depending on the Internet line being used. Adjust the bit rate within the range that does not exceed the communication bandwidth.

Starting/stopping RTMP streaming

RTMP streaming is started and stopped from the run screen of the application. When RTMP streaming is configured on the [Streaming] tab and [Codec] tab, the [Stream Now] / [Stop Stream] button is displayed on the run screen of the application.

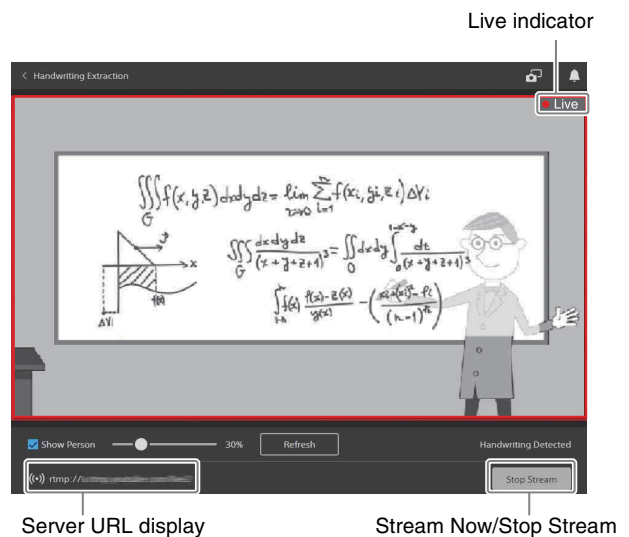

[Stream Now], [Stop Stream]

Use to start and stop streaming.

[Stream Now]: Displayed when the stream is stopped. Click the button to start streaming.

[Stop Stream]: Displayed when streaming. Click the button to stop streaming.

Server URL display

Displays the server URL during streaming. Click to display the streaming settings in a pop-up dialog.

Live indicator

Displayed when streaming. A red frame is displayed around the image being streamed.

Licenses

Configuration of licenses is required to activate option functions on the unit. The screen consists of [License] and [History] tabs.

[License] tab

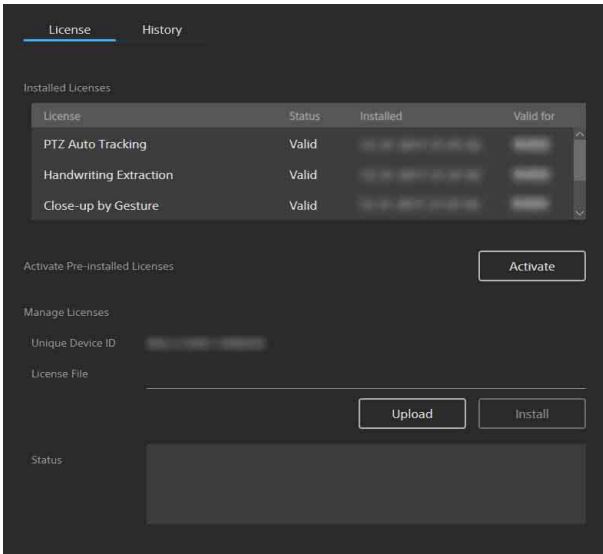

[Installed Licenses]

Displays the option function name, status, installation date and time, and validity period of installed licenses in list view.

[Activate Pre-installed Licenses]

Click the [Activate] button to run activation for the licenses pre-installed on the unit. Select the pre-installed license you want to activate, and activate it to use the option function for a limited time.

Notes

- The option function corresponding to an activated pre-installed license is enabled when the unit is restarted.
- The valid period countdown starts immediately after activation, regardless of when the unit is restarted.
- The valid period of a pre-installed license is 60 days.

[Manage Licenses]

Displays the Unique Device ID and status of the licenses.

To purchase a license and enable option functions

You can use option functions by purchasing and installing a license. Before performing this procedure, purchase the license and then obtain a purchase code.

Note

For details about purchasing licenses, contact your distributor.

Perform steps **1** and **3** on the setup screen of the unit. In step **2**, access the specified site from a web browser on a computer, and follow the instructions displayed on the screen.

1 Access the device on which to use the option function, and check [Unique Device ID] on the [License] tab of the setup screen.

2 Access “Upgrade and License Management Suite” from a web browser on the computer. URL: <https://ulms.sony.net>

2-1 Follow the instructions displayed on the screen to register a license purchase code and enter the Unique Device ID obtained in step **1**.

2-2 Download the issued license file (installation key “RQ_LIC.DAT”).

3 Perform the following operations on the setup screen.

3-1 Click the [Upload] button on the [License] tab, and select the license file (installation key “RQ_LIC.DAT”) downloaded in step **2-2**.

3-2 Click the [OK] button in the file selection dialog to import the file into the unit.

3-3 Click the [Install] button to install the license.

3-4 Restart the unit.

Notes

- The option function corresponding to the installed license is enabled when the unit restarts.
- Functions are no longer available when the valid period of period licenses has expired.
- The valid period for period licenses starts counting from the time the license is installed, regardless of whether the unit is restarted or not. The valid period is counted even if the function covered by the license is not used, including when the power is off.
- The Unique Device ID and license file are linked together. When obtaining a license file, always enter the Unique Device ID of the device on which the option function will be used.
- The license cannot be installed correctly if the Unique Device ID used to obtain the license file and the Device Unique ID of the device on which the license file is imported are different.

[History] tab

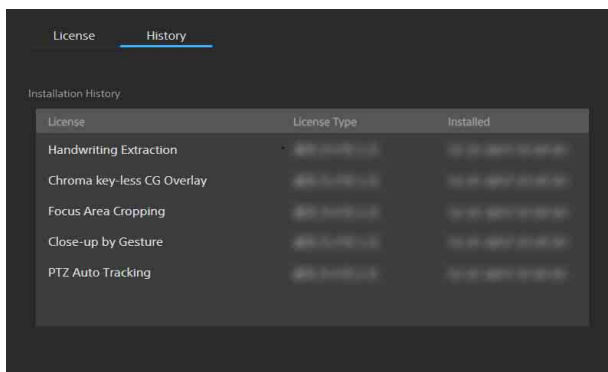

The screenshot shows the 'History' tab with a table titled 'Installation History'. The table has three columns: 'License', 'License Type', and 'Installed'. The 'License' column lists five items: 'Handwriting Extraction', 'Chroma key-less CG Overlay', 'Focus Area Cropping', 'Close-up by Gesture', and 'PTZ Auto Tracking'. The 'License Type' and 'Installed' columns contain placeholder text.

License	License Type	Installed
Handwriting Extraction		
Chroma key-less CG Overlay		
Focus Area Cropping		
Close-up by Gesture		
PTZ Auto Tracking		

Displays the log of the installed licenses. You can check the option function name, license type, and installation date and time for each license.

System

Use to configure the basic system settings of the unit. The screen consists of [Information], [Date & Time], [Initialize], [Update], [EULA], and [Software] tabs.

[Information] tab

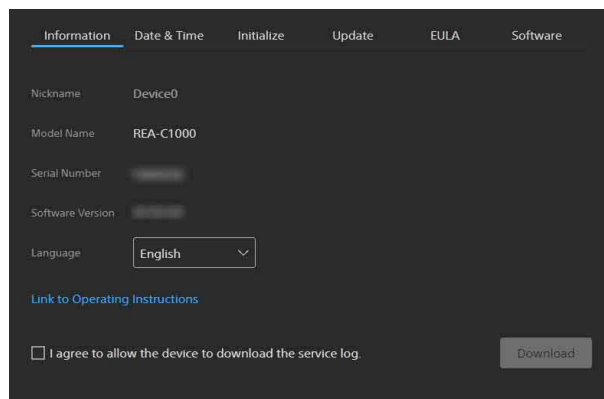

The screenshot shows the 'Information' tab with the following fields and options:

- Nickname: Device0
- Model Name: REA-C1000
- Serial Number: [Redacted]
- Software Version: [Redacted]
- Language: English (dropdown menu)
- Link to Operating Instructions (blue link)
- I agree to allow the device to download the service log.
- Download button

[Nickname]

Displays the name of the device configured using RM-IP Setup Tool.

[Model Name]

Displays the model name of the unit.

[Serial Number]

Displays the serial number of the unit.

[Software Version]

Displays the software version of the unit.

[Language]

Specify the display language of the screen. You can select [Japanese], [English], or [Chinese].

[Link to Operating Instructions]

Click the link to display the Operating Instructions (this document).

To download the service log

You can download device information as a service log used for service.

Place a check mark in [I agree to allow the device to download the service log.] to enable the [Download] button.

Click the [Download] button, then follow the instructions in the displayed dialog to select a folder and save the service log of the unit.

[Date & Time] tab

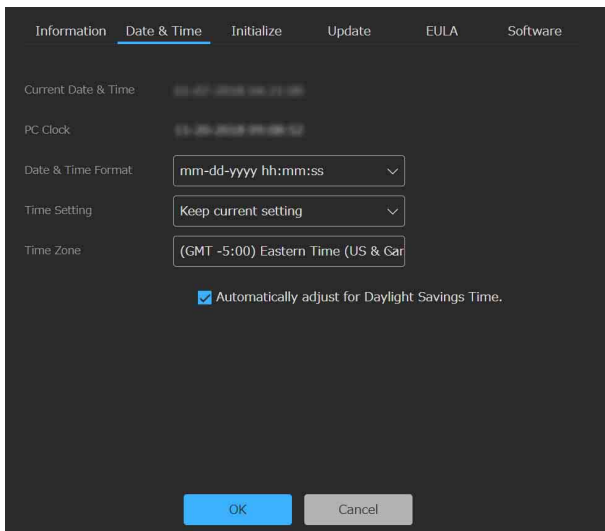

[Current Date & Time]

Displays the set date and time of the unit.

Note

The date and time set at the time of purchase may not be accurate. Always check the setting.

[PC Clock]

Displays the date and time of the computer being used.

[Date & Time Format]

Select the date and time format to display.

You can select [yyyy-mm-dd hh:mm:ss], [mm-dd-yyyy hh:mm:ss], or [dd-mm-yyyy hh:mm:ss].

[Time Setting]

Select the method for setting the date and time.

[Keep current setting]: Select to keep the current settings for the date and time of the unit.

[Synchronize with PC]: Select to synchronize the date and time of the unit with the date and time of the computer.

[Manual Setting]: Select to set the date and time of the unit manually. Specify a value in the [Current Date & Time] field.

[Synchronize with NTP]: Select to synchronize the date and time of the unit with the NTP (Network Time Protocol) server of a time server. If you select [Synchronize with NTP], specify the NTP server.

[NTP Server]

Synchronize using the entered NTP server address.

[Time Zone]

Set the time zone for the region in which the unit is installed relative to Greenwich Mean Time.

Note

If the time zone selected in [Time Zone] and the time zone of the computer are different, a date and time reflecting the difference in time zones is set on the unit.

To adjust for Daylight Savings Time automatically

Place a check mark in [Automatically adjust for Daylight Savings Time.] to automatically adjust the time for daylight savings time (summer time) in the selected time zone.

[Initialize] tab

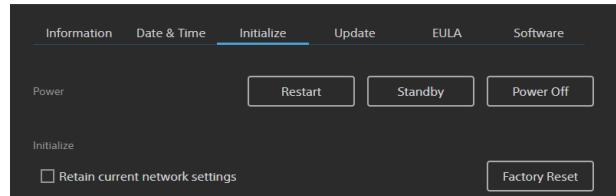

[Restart]

Click the [Restart] button when you want to restart the unit. Click the [OK] button in the displayed confirmation dialog to restart the unit.

[Standby]

Click the [Standby] button to switch the unit to standby state. In standby state, the input and output of video and audio stops.

When the [Standby] button is clicked, a screen indicating standby state appears. Click the [On] button on the screen to release standby state.

[Power Off]

Click the [Power Off] button when you want to shut down the unit. Click the [OK] button in the displayed confirmation dialog to shut down the unit.

Press the POWER button on the unit when you want to turn the unit on again.

[Factory Reset]

Use this when you want to reset the unit to the factory default settings. Click the [Factory Reset] button, and click the [OK] button in the displayed confirmation dialog to reset the settings to the factory default settings and restart the unit.

You can reset the unit to its factory default settings using the buttons on the unit (page 6).

To retain network settings

Place a check mark in [Retain current network settings] to retain only the current network settings when resetting the unit to the factory default settings. The corresponding items are configured on the [Network] and [Security] pages.

Notes

- Information relating to option function licenses is retained even when a factory reset is performed.
- To protect customer information, reset the settings of this unit to the factory settings when lending or transferring the unit to another person and when disposing of the unit.

[Update] tab

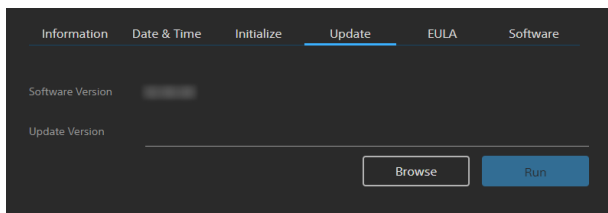

Use this to check and update the software version of the unit.

To update the software

Click the [Browse] button, select the firmware update file, and click the [Run] button.

The unit restarts automatically, and the update is executed.

[EULA] tab

Displays the EULA (End User License Agreement).

[Software] tab

Displays the software licenses used by the unit.

Application Setup and Operation

Note

Option functions must be enabled before configuring or running an application. To enable an option function, you must activate a pre-installed license or purchase and install a license. For details, see “[License] tab” (page 24).

Configuring an Application

Configure application settings before running an application. This configuration is performed by the administrator.

Note

Connect the unit and external devices before configuring the application. Disconnecting and reconnecting an HDMI cable, turning HDMI devices on/off, or switching video signals while configuring or running an application may prevent the settings from being configured successfully or adversely affect the video output from the unit.

1 Access the unit from a web browser.

For details about accessing the unit, see “Accessing the Unit from a Web Browser” (page 11).

2 Select the application.

Select the applications to use for [Camera 1] and [Camera 2] from [Applications]. When applications are selected for both [Camera 1] and [Camera 2], both applications can be run simultaneously. However, the applications that can be run simultaneously are restricted to the following.

- PTZ Auto Tracking
- Handwriting Extraction

The camera or other video device connected to [HDMI IN 1] in [Input/Output] (page 14) becomes the input video source of the application specified for [Camera 1]. Similarly, the camera or other video device connected to [HDMI IN 2] becomes the input video source of the application specified for [Camera 2].

3 Click the [Setup] button.

The application starts, and the setup screen for the application appears.

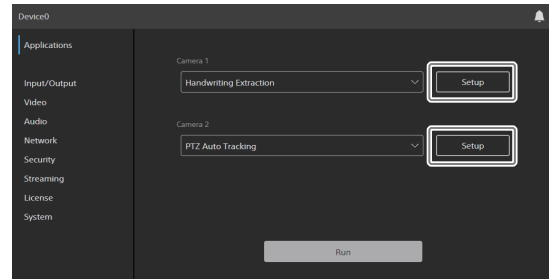

Common application setup operation

You can configure an application using the setup wizard help guide displayed on the screen.

Press the [Next] button to move to the next screen of the setup wizard, or the [Back] button to return to the previous screen. Click the [Done] button to complete the configuration.

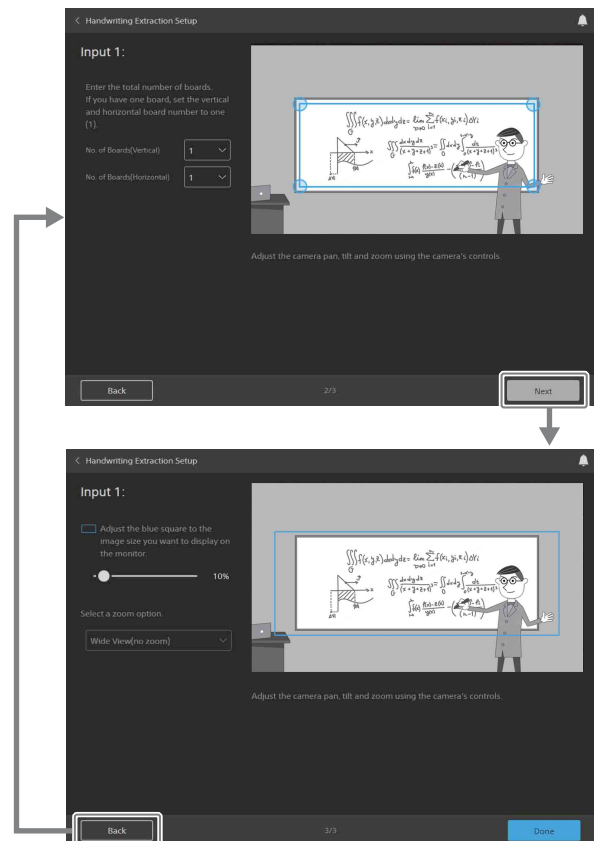

Running an application

After configuring an application, click the [Run] button on the application screen to run the application.

If an application is selected only for [Camera 1] from [Applications], only the image for the running application is displayed on the screen.

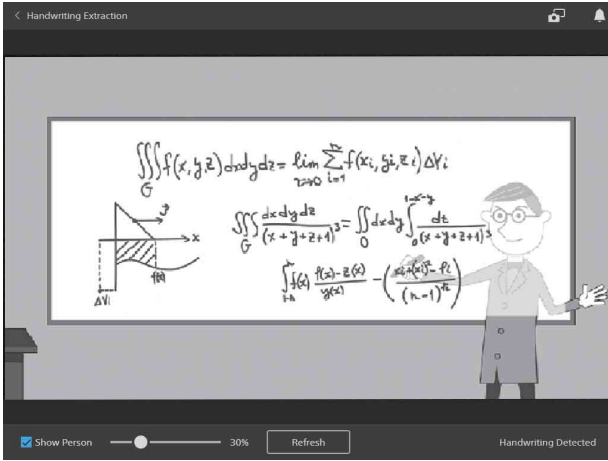

If applications are selected for both [Camera 1] and [Camera 2] from [Applications], the images for both running application are displayed on the screen.

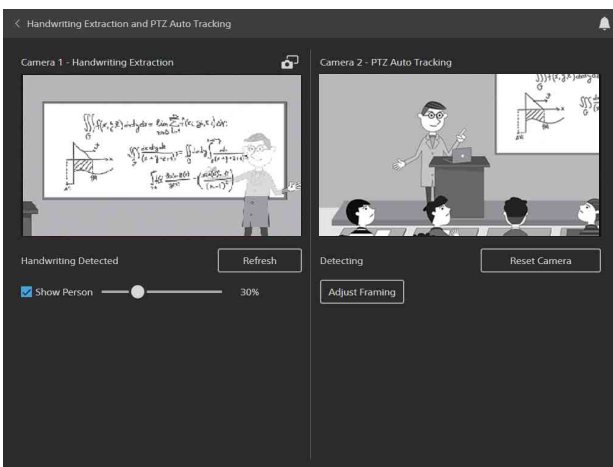

To exit an application

While configuring or running an application, click [**<**] at the top left of the screen or turn off the unit.

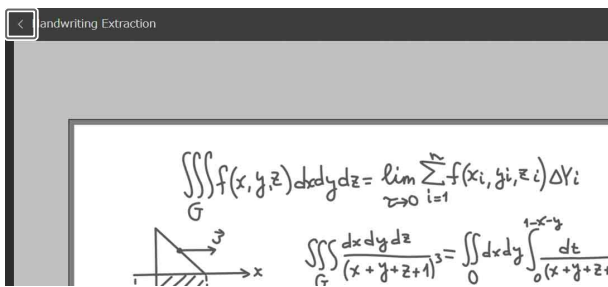

Tip

If the unit is turned off while an application is running, the application will automatically restart the next time the unit is accessed.

Handwriting Extraction Application

This application identifies and extracts text and diagrams drawn on a whiteboard or blackboard in real-time, and renders them so that they appear in front of the speaker.

Note

The Handwriting Extraction option function must be enabled before configuring or running the Handwriting Extraction application. Activate the corresponding pre-installed license, or purchase and install a license.

Preparation before setup

Important

Adjust the focus of the camera manually so that the whole view of the blackboard or whiteboard to extract is in focus. Adjust the white balance and exposure manually according to the usage environment.

1 Connect the camera and the device to which to output the extracted result image to the unit.

Connect according to [Camera 1] or [Camera 2] for which [Handwriting Extraction] is specified from [Applications].

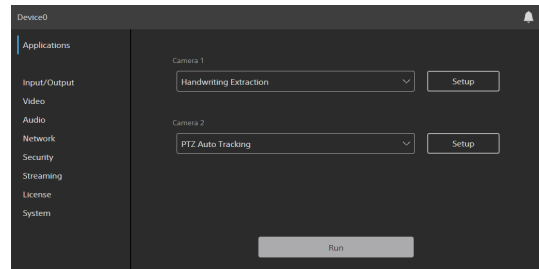

Note

Connect the unit and remote camera to a network so that they can communicate using VISCA over IP to control the camera from the unit. Connect using a network connection, as shown in “System Configuration” (page 7). The Handwriting Extraction application also functions when not connected to a network, but the performance of the text and diagram extraction function may be reduced.

When running the Handwriting Extraction application standalone:

Select [Handwriting Extraction] for [Camera 1] from [Applications]. Do not select the application for [Camera 2].

The camera and video output device connection is shown below.

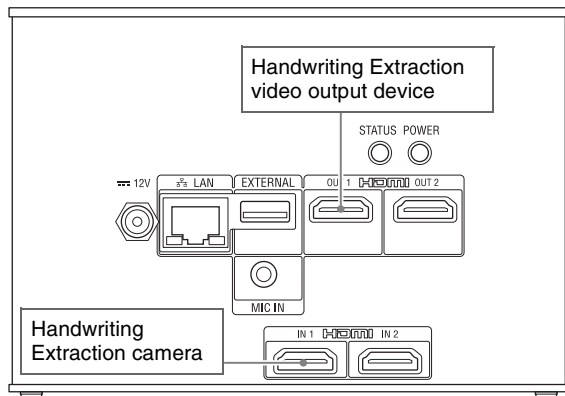

When running together with the PTZ Auto Tracking application:

When [Handwriting Extraction] is selected for [Camera 1] and [PTZ Auto Tracking] for [Camera 2] from [Applications], the camera and video output device connection is shown below.

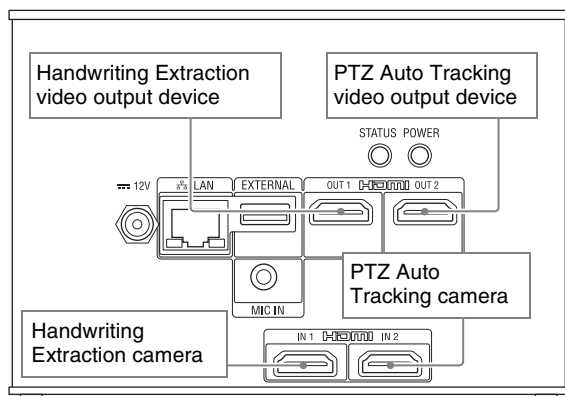

When [PTZ Auto Tracking] is selected for [Camera 1] and [Handwriting Extraction] for [Camera 2] from [Applications], the camera and video output device connection is shown below.

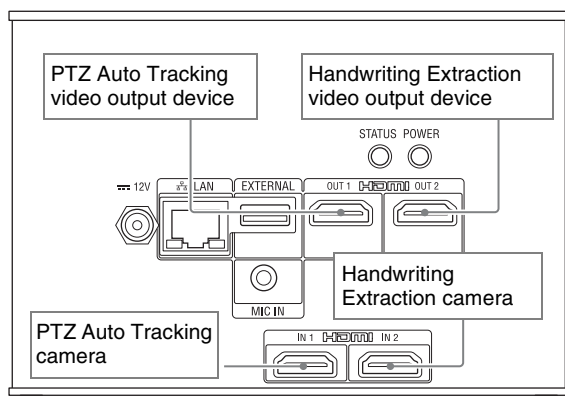

When using the RTMP streaming function:

The same video as the output on HDMI OUT is streamed to a streaming service via LAN cable. Set [HDMI OUT1] or [HDMI OUT 2] in [Streaming Output 1] on the [Codec] tab (page 23) according to the connection destination of the output device.

2 Turn on the camera and peripheral devices.

Notes

- Adjust the position and field of view of the camera so that the blackboard or whiteboard fits within the field of view of the camera.
- In the Handwriting Extraction application, if the exposure and white balance function of the connected camera can be controlled by the unit, then the unit may automatically adjust the exposure and white balance of the camera according to the shooting environment. If you don't want the unit to adjust the exposure and white balance, click [Advanced] on the setup screen and place a check mark in [Override Camera's Auto Controls].

For details about supported cameras, see "Supported Cameras and Available Camera Functions" (page 54).

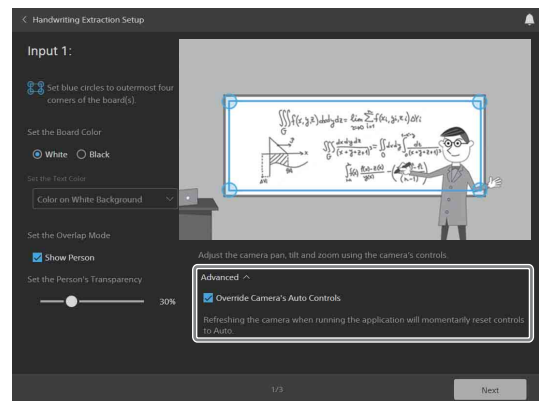

Configuring the Handwriting Extraction application

1 Select [Handwriting Extraction] from [Applications].

2 Click the [Setup] button.

The setup screen appears. A preview of the image from the camera connected to the HDMI IN 1 connector is displayed on the screen.

Note

If the camera image is not displayed, there may be a problem with the camera connection or settings. Check the connection and settings again.

3 Configure the following settings.

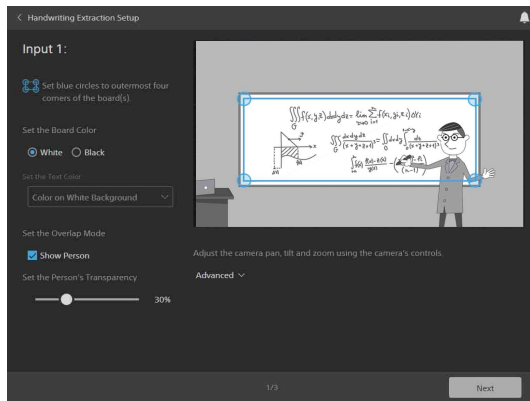

If there are multiple blackboards or whiteboards, select the extraction range as shown on the following screen (example with two horizontal and two vertical boards).

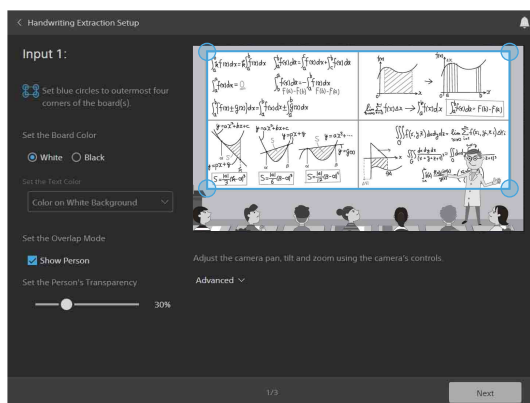

Extraction range

Move the four blue circles displayed on the preview screen to select the target area (blackboard or whiteboard) to extract. Take care to not select the parts of the blackboard or whiteboard, such as the frame, not related to the writing on the board.

Board color

Select the type of board for extraction.

[White]: White surface used for writing, such as a whiteboard

[Black]: Dark surface used for writing, such as a blackboard

Text color

Select the text color and background color when extracting text written on a blackboard. This setting is enabled only when the board color is set to [Black].

[Color on White Background]: White text is output as black text, and non-white text is output in color. The background color is white.

[Color on Black Background]: White text is output as white text, and non-white text is output in color. The background color is black.

[Monochrome on White Background]: Text is output in black. The background color is white.

[Monochrome on Black Background]: Text is output in white. The background color is black.

Overlap mode

Select whether to superimpose an image of the person in the output over the writing when extracting the handwriting.

You can change the overlap mode using the [Show Person] checkbox. When the checkbox is cleared, only the handwriting is extracted.

When [Show Person] is checked: Superimpose an image of the person writing at the same time when extracting the handwriting.

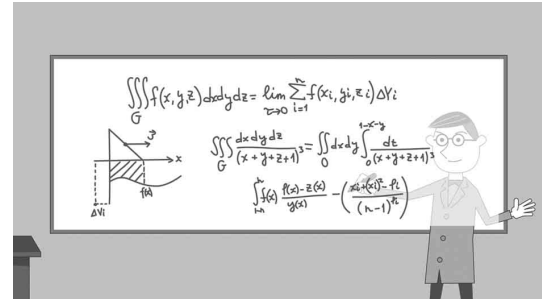

When [Show Person] is cleared: Output the handwriting extraction only.

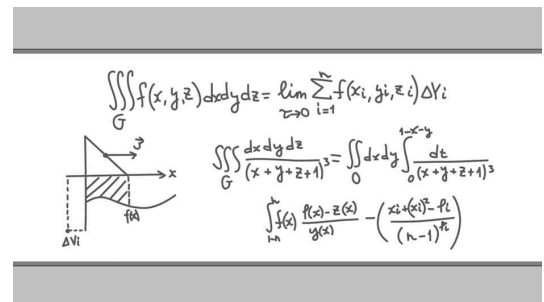

Person's transparency

When the overlap mode is set to [Show Person], set the transparency of the person to be superimposed by sliding the bar left/right.

Override auto exposure controls

Click [Advanced] to display [Override Camera's Auto Controls].

This is enabled when a camera that supports control of the exposure and white balance functions of the camera by the unit is connected. To prevent adjustment of the white balance and exposure of the camera from the unit, insert a check mark.

For details about supported cameras, see "Supported Cameras and Available Camera Functions" (page 54).

4 When finished, click the [Next] button.

5 Set the number of boards.

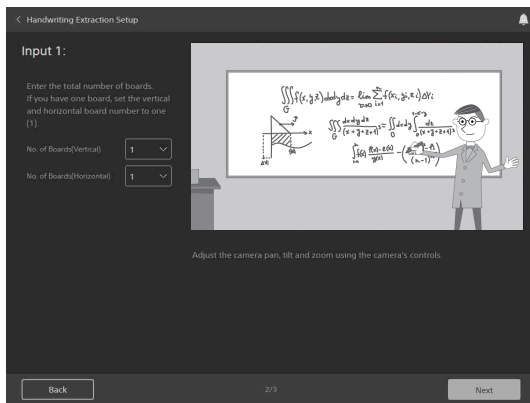

[No. of Boards(Vertical)]

Set the total number of boards in the vertical direction to extract.

[No. of Boards(Horizontal)]

Set the total number of boards in the horizontal direction to extract.

The following example shows a configuration with two vertical and two horizontal boards.

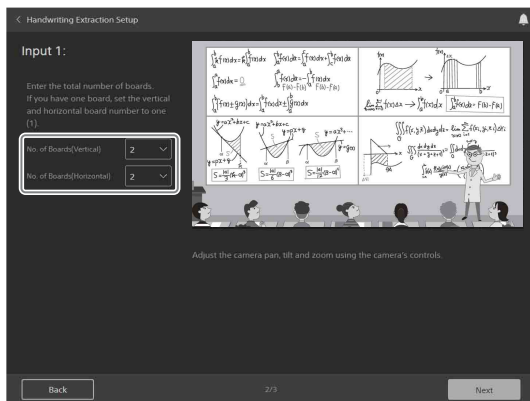

6 When finished, click the [Next] button.

7 Set the output image.

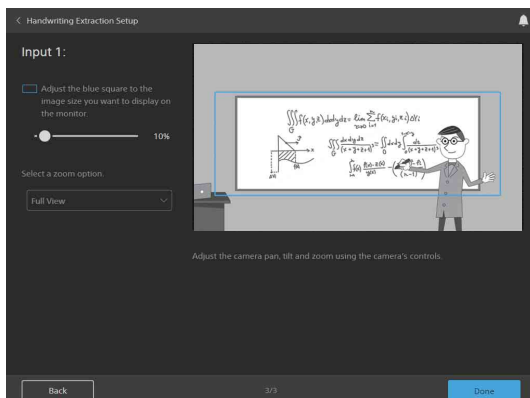

If you want to capture not just the extraction range but also the person, the output range must be widened keeping the extraction range in the center. The output range is displayed by a blue frame on the preview screen. Move the bar left/right to change

the output range with the extraction range in the center.

This setting is enabled when the overlap mode is set to [Show Person].

8 Set the extraction field of view.

Select the output display result. When used together with PTZ Auto Tracking, only [Full View] can be selected.

[Full View]: Output the entire extraction range.

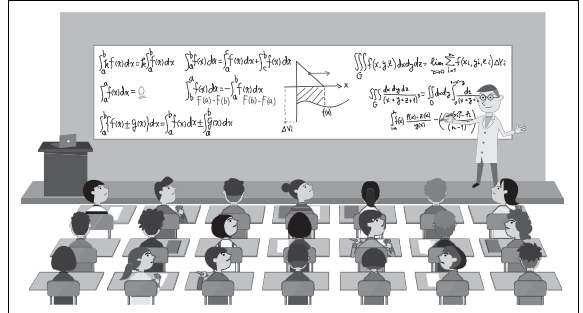

[Cropped View]: Can be selected when [No. of Boards(Vertical)] is set to 1. Divide the extraction range by the value of [No. of Boards(Horizontal)], and the position containing the person is output. When [No. of Boards(Horizontal)] is set to 1, the number of divisions is automatically determined from the entire extraction area and margin ratio. When [No. of Boards(Horizontal)] is set to 2 or higher, the area is divided by the number of boards in the horizontal direction.

The following shows an example of crop division with cropped field of view and a display example at the cropped field of view.

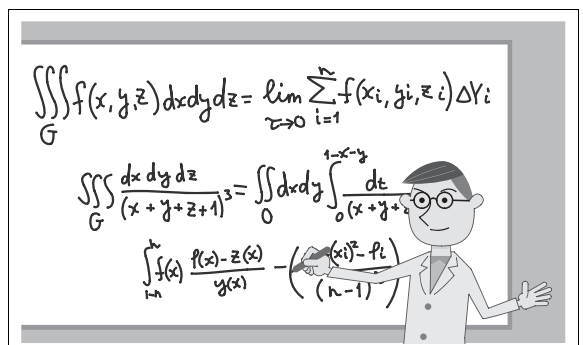
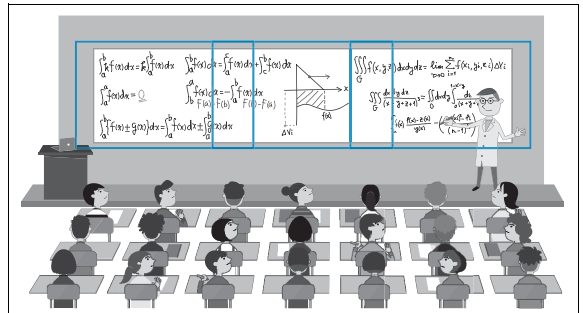

[Crop at Center of Board]

When the output field of view is set to [Cropped View], insert a check mark in [Crop at Center of Board] so that the cropped image is centered at the center of the extraction area horizontally.

[Crop at Center of Board] is enabled when [Number of Boards(Horizontal)] and [Number of boards(Vertical)] are both set to 1 for the horizontal extraction range and the number of divisions is set to an even number in [Cropped View].

Note

[Crop at Center of Board] cannot be selected when the number of divisions is set to an odd number in [Cropped View].

For example, if the number of division is set to 4 and a check mark is placed in [Crop at Center of Board], the extraction range is divided by 3.

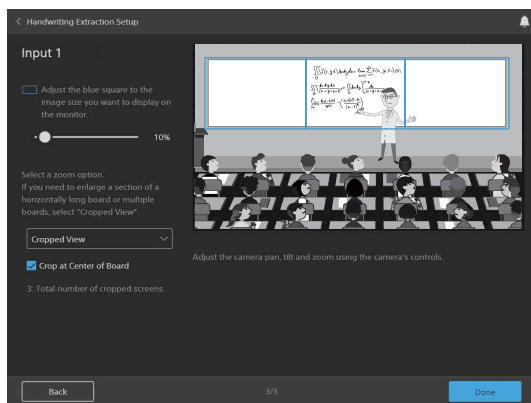
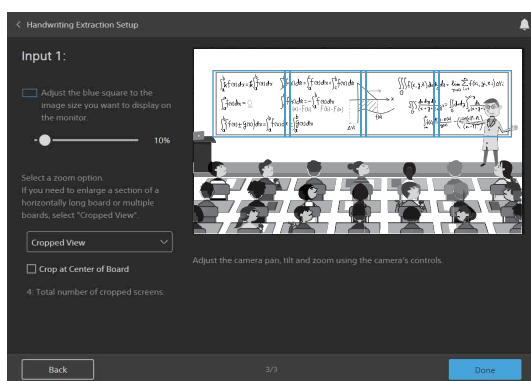

This setting is useful when you want to capture a speaker who has a high probability of staying in the center of the angle of view, such as when the blackboard or whiteboard is horizontally long but only the center part is used.

[Variable View]: Can be selected when [No. of Boards(Vertical)] is set to 2. This mainly outputs a wide angle view image, but also zooms and crops the position where the person is located every few minutes.

The following shows a display example with wide field of view and a display example at the zoom field of view.

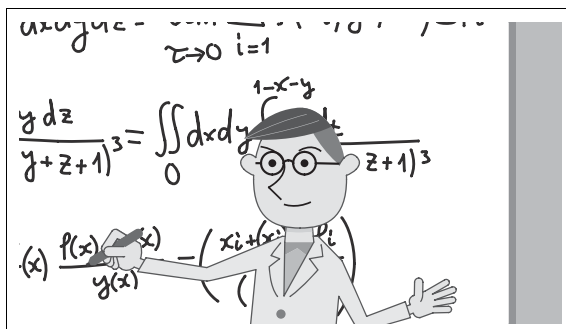
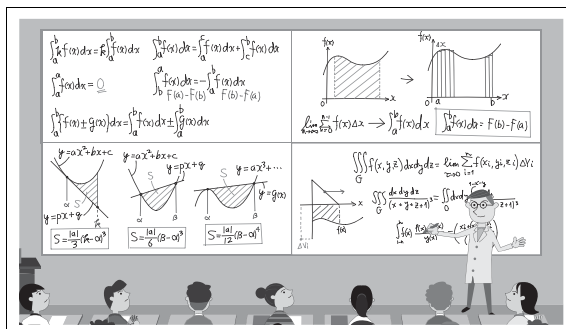

Note

When [Cropped View] or [Variable View] is selected, if a face is partially obscured, due to wearing a mask or other reason, appropriate operation may not be possible.

- 9 When finished, click the [Done] button. The setup is saved in the unit.

Running the Handwriting Extraction application

Run this application to extract text and drawings from a specified drawing board area from the input video and then output the extracted video.

- 1 Select [Handwriting Extraction] from [Applications].
- 2 Click the [Run] button. The run screen appears.

You can check the video that is output using the preview image while the application is running.

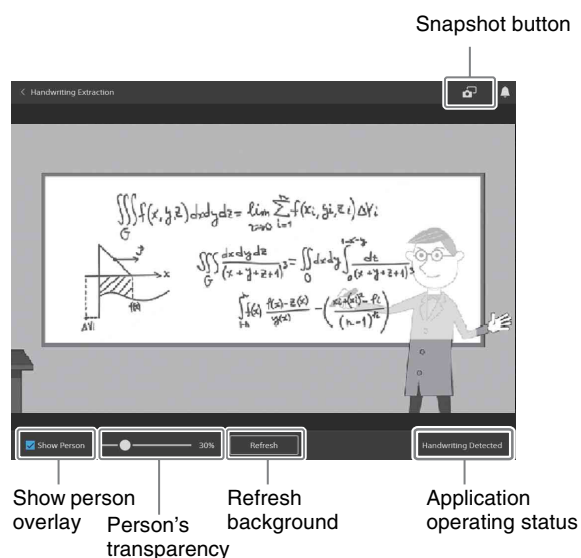

Notes

- Extraction may not start immediately after starting the application due to extraction preprocessing.
- When running, you can change the overlap mode and person's transparency. However, the changes are not saved in the settings.
- During extraction, the extraction may not be successful if there are changes in the environment, such as changes in the brightness of the room.
- The extraction may not be successful depending on the resolution of the input image.

Snapshot button

You can click the button to download an extracted image (an image without the person overlay) as an image file. The image file is a wide view when the output field of view is set to [Full View] or [Variable View], and a cropped image when set to [Cropped View].

Show Person

Insert a check mark to display the person superimposed on the extracted handwritten content for output. The person is reflected in the output only while the application is running.

To superimpose the person all the time, place a check mark in [Show Person] (page 31) on the Handwriting Extraction application setup screen.

Person's transparency

Set the transparency used when superimposing the person. The person is reflected in the output only while the application is running.

To use the same transparency person all the time, place a check mark in [Person's transparency] (page 31) on the Handwriting Extraction application setup screen.

Refresh background

Performs the extraction process immediately.

Application operating status

Displays the application operating status.

[Handwriting Detected]: The contents on the drawing board are being extracted.

[Trying to Detect Handwriting]: Extraction cannot be achieved successfully at the current time. Reset the extraction result up to the current time, and start extracting again.

You can click the snapshot button in the top right of the screen to download an extracted image as an image file.

PTZ Auto Tracking Application

This application tracks a moving target, and automatically moves a remote camera to maintain optimum compositing while shooting. Use a remote camera that supports remote control of the pan, tilt, and zoom functions for the PTZ Auto Tracking application.

Note

The PTZ Auto Tracking option function must be enabled before configuring or running the PTZ Auto Tracking application. Activate the corresponding pre-installed license, or purchase and install a license.

Preparation before setup

- 1 Connect the camera and the device to which to output the tracking result image to the unit.

Connect according to [Camera 1] or [Camera 2] for which [PTZ Auto Tracking] is specified from [Applications].

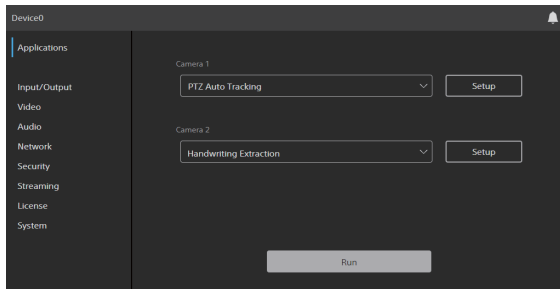

Note

Connect the unit and remote camera to a network so that they can communicate using VISCA over IP to control the camera from the unit. Connect using a network connection, as shown in “System Configuration” (page 7).

When running the PTZ Auto Tracking application standalone:

Select [PTZ Auto Tracking] for [Camera 1] from [Applications]. Do not select the application for [Camera 2].

The camera and video output device connection is shown below.

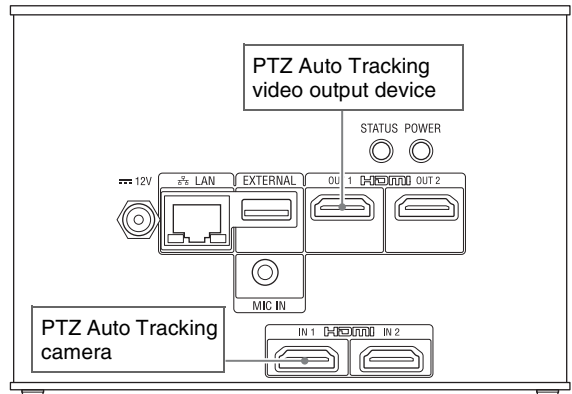

When running together with the Handwriting Extraction application:

When [PTZ Auto Tracking] is selected for [Camera 1] and [Handwriting Extraction] for [Camera 2] from [Applications], the camera and video output device connection is shown below.

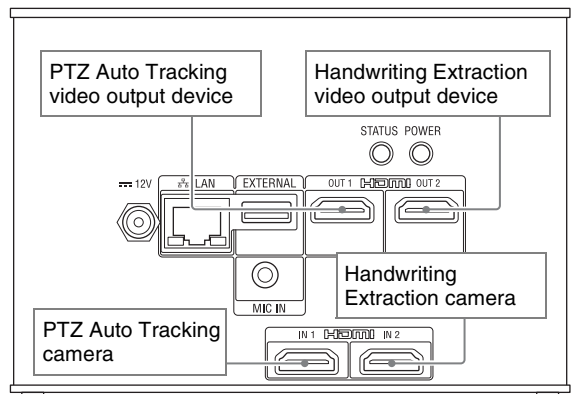

When [Handwriting Extraction] is selected for [Camera 1] and [PTZ Auto Tracking] for [Camera 2] from [Applications], the camera and video output device connection is shown below.

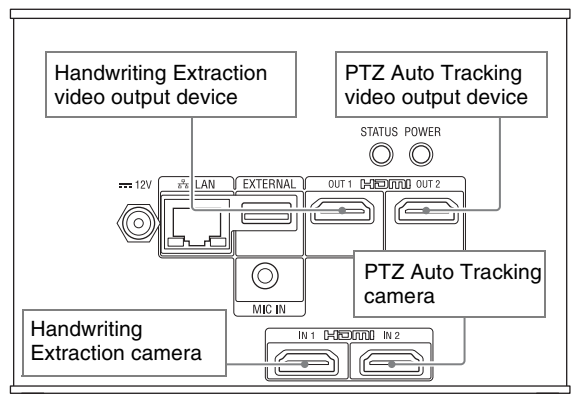

When using the RTMP streaming function:

The same video as the output on HDMI OUT is streamed to a streaming service via LAN cable. Set [HDMI OUT 1] or [HDMI OUT 2] in [Streaming Output 1] on the [Codec] tab (page 23) according to the connection destination of the output device.

2 Turn on the camera and peripheral devices.

Notes

- The settings of the remote camera to be connected must be configured beforehand as described in “Input/Output” (page 14).
- It is recommended that the focus, white balance, and exposure of the remote camera be set to Auto beforehand.
- The zoom function of the remote camera uses the optical zoom range only.
- Use these settings as the defaults on remote cameras that can set the pan/tilt speed type and zoom speed type.
- Remote camera settings may be changed from the unit while the application is running.
- For details about remote cameras that support the PTZ Auto Tracking application, see “Supported Cameras and Available Camera Functions” (page 54).
- SRG-300H devices with some serial numbers may not operate. For details, contact your distributor.

Configuring the PTZ Auto Tracking application

1 Select [PTZ Auto Tracking] from [Applications].

2 Click the [Setup] button.

The setup screen appears.

A preview of the image from the camera is displayed on the screen. When [PTZ Auto Tracking] is selected for [Camera 1] from [Applications], the image from the camera connected to the HDMI IN 1 connector is displayed. When selected for [Camera 2], the image from the camera connected to the HDMI IN 2 connector is displayed.

Note

If the camera image is not displayed, there may be a problem with the camera connection or settings. Check the connection and settings again.

Camera PTZ (pan, tilt, zoom) operation

You can control the PTZ movement of the camera on each of the following setup screens. The controls are common to all screens, but PTZ operations may be grayed out depending on the settings.



3 Configure the following settings.

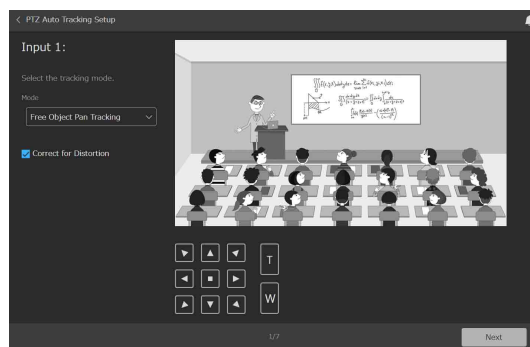

Tracking mode

Select the tracking mode used for automatic tracking.

[Free Object Pan Tracking]: Track the person moving to the left/right in front of the blackboard or screen.

[Fixed Frame Pan Tracking]: Track the person moving to the left/right in front of the blackboard or screen while giving priority to keeping the contents of the board within the field of view.

Distortion correction

If the screen movement does not stay level when panning, due to the remote camera position, size of the room, or other setup conditions, enable [Correct for Distortion] so that the screen motion stays level.

Note

To apply the appropriate correction, set appropriate values for the camera position setup in step 5.

4 When finished, click the [Next] button.

5 Configure the following settings.

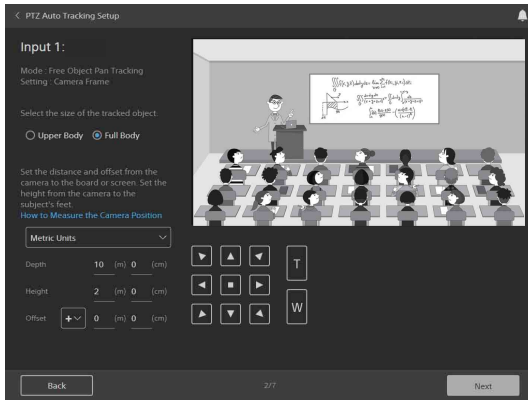

Tracking object size

Select the size of the object to keep within the image during tracking.

This can be configured when the tracking mode is set to [Free Object Pan Tracking]. It is not displayed when the tracking mode is set to [Fixed Frame Pan Tracking].

[Full Body]: Keep the full body of the person to be tracked within the image.

[Upper Body]: Keep the upper half of the person to be tracked within the image.

Camera position

Set the distance from the remote camera to the blackboard or screen, the height from the person's feet, and the offset.

[Depth]: Specify the horizontal distance from the remote camera to the blackboard or screen (refer to "Depth" dimension in the following diagram).

[Height]: Specify the vertical distance from the feet of the person to be tracked to the remote camera (refer to "Height" dimension in the following diagram).

[Offset]: Specify the horizontal offset distance when the remote camera forward direction (0° pan angle direction) is at an angle to the perpendicular line from the blackboard or screen (refer to "Offset" dimension in the following diagram).

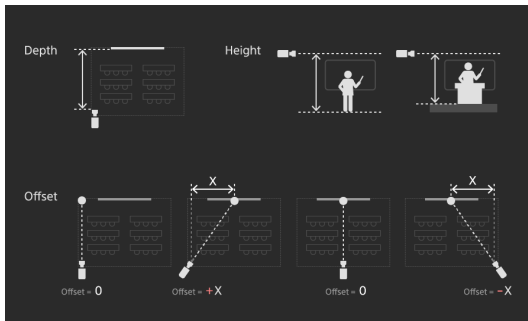

Tips

- The person to be tracked is assumed to move across the front of the blackboard or screen.
- Select the units for Depth, Height, and Offset when entering values.

- The horizontal offset distance is 0 when the remote camera forward direction (0° pan angle direction) is parallel to the perpendicular line from the blackboard or screen (directly opposite).
- When the tracking mode is set to [Free Object Pan Tracking], the unit automatically controls the zoom position of the remote camera and determines the field of view in the zoom direction.

6 When finished, click the [Next] button.

7 Configure the following settings.

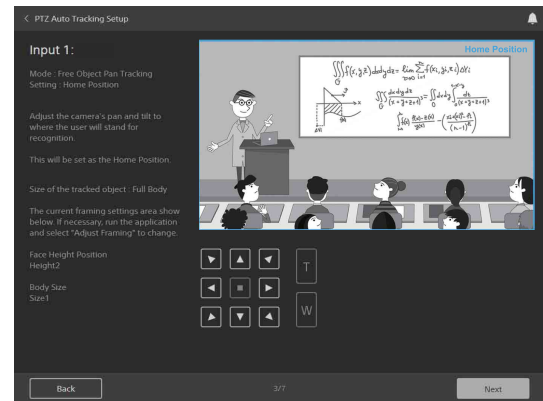

Home position

Operate the remote camera using the PTZ controls to move to the camera position (home position) where detection of a person will start. Tracking operation starts from the home position.

Face Height Position

Displays the set value of the height of the face of the person to be tracked set by the framing adjustment. You can adjust the framing while the application is running (page 40).

Body Size

Displays the set value of the size of the person to be tracked set by the framing adjustment. You can adjust the framing while the application is running (page 40).

Note

When the tracking mode is set to [Fixed Frame Pan Tracking], the recovery position (page 39) cannot be set, so set the home position while taking the area of the board to keep within the image during tracking into consideration. Also, set the home position while taking the detection area within the home position, set in step 9, into consideration.

8 When finished, click the [Next] button.

9 Configure the following settings.

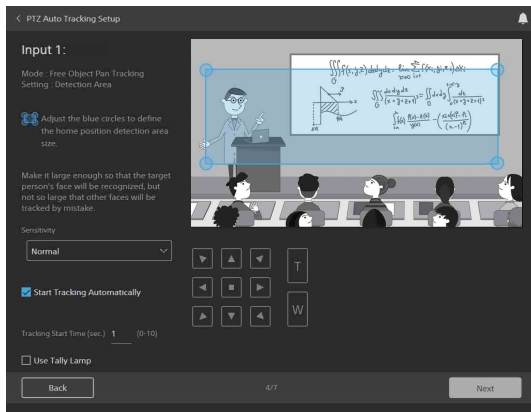

Detection area

Move the four blue circles displayed on the preview screen to mark the detection area for tracking within the home position.

A person will be tracked when they enter this area.

Sensitivity

Set the response sensitivity for tracking when the person to track starts to move.

[Normal]: Respond with standard sensitivity.

[Sensitive]: Respond with higher sensitivity than the [Normal] setting.

Start tracking automatically

Place a check mark in [Start Tracking Automatically] to automatically start tracking when a person is detected within the home position detection area. Leave the checkbox empty when you want to start tracking manually.

Also, always set [Tracking Start Time] for automatic tracking.

Tracking start time

Automatic tracking starts when a person has been captured continuously for a duration exceeding the time set in [Tracking Start Time].

Tracking tally lamp

Enabled when a camera equipped with a tally lamp is connected. Insert a check mark to turn on the tally lamp of the tracking camera.

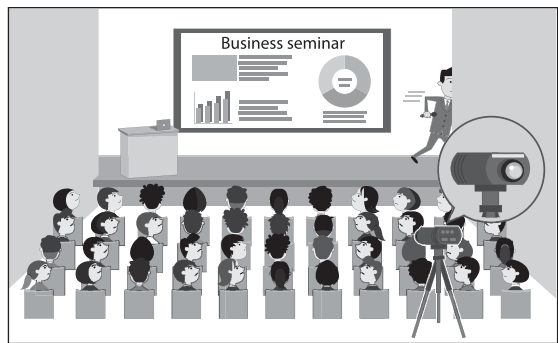
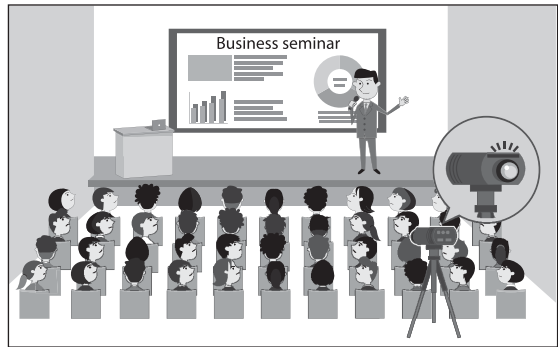

For details about cameras that support this function, see “Supported Cameras and Available Camera Functions” (page 54).

10 When finished, click the [Next] button.

11 Configure the following settings.

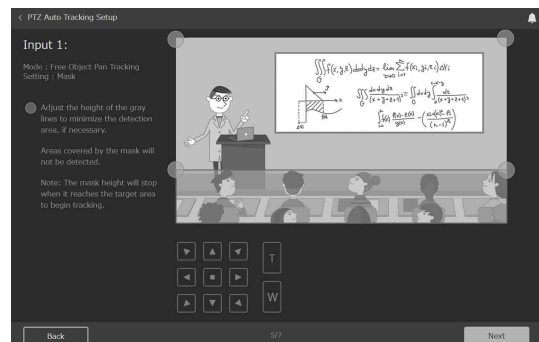

Mask

Set the mask areas in order to prevent false detection of objects other than the person to be tracked during tracking.

Move the four gray circles displayed on the preview screen, as required, to adjust the height to effectively narrow the detection area during tracking.

The mask areas are excluded from the detection target during tracking.

Note

The mask areas must not cover the area specified for the home position detection area.

12 When finished, click the [Next] button.

13 Configure the following settings.



PTZ limits

Specify the range of the pan operation of the camera during tracking. If a range is not specified or the specified range is invalid, the unit automatically sets the range for pan operations.

This can be configured when the tracking mode is set to [Free Object Pan Tracking]. It is not configurable when the tracking mode is set to [Fixed Frame Pan Tracking].

14 When finished, click the [Next] button.

15 Configure the following settings.

When the tracking mode is set to [Free Object Pan Tracking]

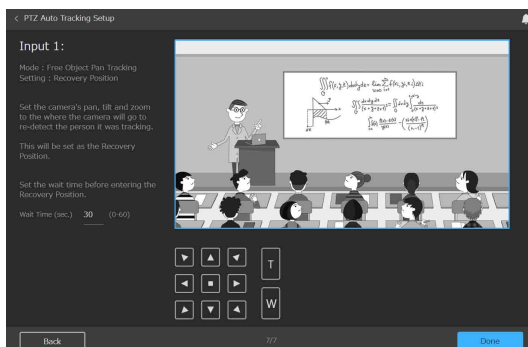

Recovery position

Set the camera position, using the PTZ controls, to move the camera to where detection is resumed when the person is no longer visible and tracking is lost during tracking.

This can be configured when the tracking mode is set to [Free Object Pan Tracking]. It is not configurable when the tracking mode is set to [Fixed Frame Pan Tracking].

After tracking is lost, the camera moves to the recovery position and detection restarts. After redetection, tracking restarts automatically when a person has been captured continuously for a duration exceeding the time set in [Tracking Start Time].

Note

It is recommended that you set the camera view for the recovery position to a slightly wider view than the home position, but re-detection and tracking may not start correctly depending on the configured position.

Tracking lost wait time

Set the wait time from when the person being tracked is no longer visible until tracking is deemed to be lost.

This can be configured when the tracking mode is set to [Free Object Pan Tracking]. It is not configurable when the tracking mode is set to [Fixed Frame Pan Tracking].

When the tracking mode is set to [Fixed Frame Pan Tracking]

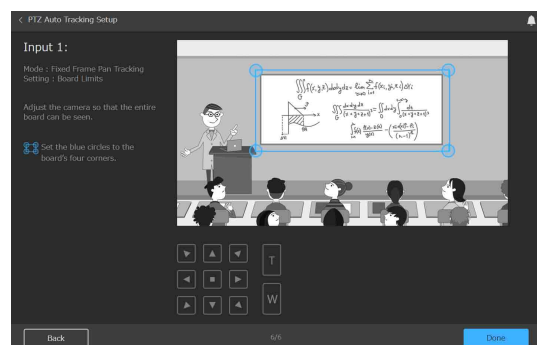

Board limits

When the tracking mode is set to [Fixed Frame Pan Tracking], the person is tracked while moving left/right in front of the blackboard or screen while giving priority to keeping the contents of the board within the field of view.

Move the four blue circles displayed on the preview screen to set the board limits to define the capture area to be maintained on the screen when panning.

16 When finished, click the [Done] button.

The setup is saved in the unit.

Running the PTZ Auto Tracking application

Run this application to track a person captured by the camera, according to the setup, and to output the tracking image.

Note

If a face is partially obscured, due to wearing a mask or other reason, appropriate tracking may not be possible.

1 Select [PTZ Auto Tracking] from [Applications].

2 Click the [Run] button.

The run screen appears.

You can check the video that is output using the preview image while the application is running.

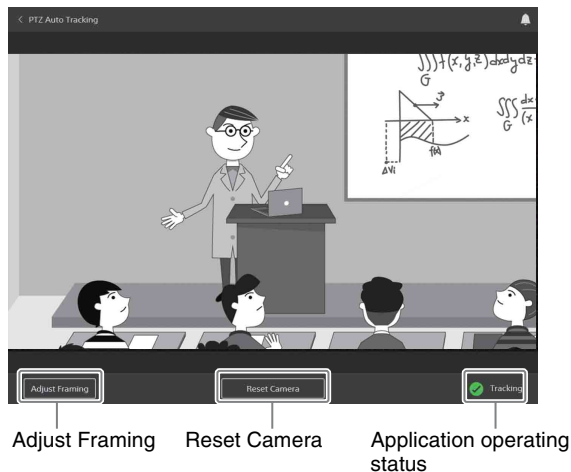

Adjust Framing

You can adjust the height and size of the tracking target within the screen. Click the button to display the adjustment screen. Select the height in [Face Height Position] and the size in [Body Size], then click the [OK] button.

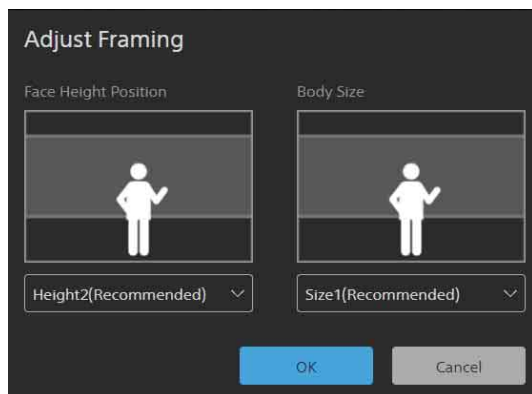

<Before adjustment>



<After adjustment>

Reset Camera

Tracking a person may not be successful occasionally, depending on their movement or clothing. When the unit can no longer track correctly, the unit automatically attempts to re-detect a person. You can also click the [Reset Camera] button to restart tracking detection from the home position.

Application operating status

Displays the application operating status.

[Detecting]: Person is detected at the home position. A face frame is attached to the person.

[Tap on Target Face]: In this state, you can select the face frame of a person to be tracked manually. Select a face frame.

[Tracking]: Person was detected and is being tracked.

[Target Lost]: Person being tracked is no longer visible and tracking has been lost. If the tracking mode is set to [Free Object Pan Tracking], the camera moves to the recovery position and detection restarts.

To start tracking manually

When [Start Tracking Automatically] is disabled, you must select the person to be tracked manually while the application is in the [Tap on Target Face] state.

When [Start Tracking Automatically] is enabled, you can also select a person while the application is in the [Detecting] state, before tracking normally starts, to start tracking that person manually.

In either case, select a displayed face frame to select the target.

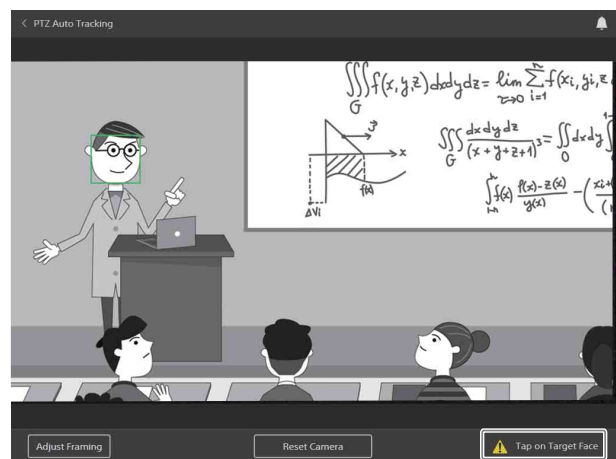

Close-up by Gesture Application

This application interprets specific gestures of people in the video, and automatically zooms in on the corresponding area. You can display two images (a wide angle view and zoomed view) in real-time.

The function is triggered on when a person stands up from a seated position. The application electronically zooms in on the area around that person (a close-up) and outputs the zoomed image. When the person sits down, the function is triggered off, the zoom is canceled, and the image returns to the previous state. The original image can also be output at the same time as the zoomed image.

Note

The Close-up by Gesture option function must be enabled before configuring or running the Close-up by Gesture application. Activate the corresponding pre-installed license, or purchase and install a license.

Preparation before setup

1 Connect a camera to the HDMI IN 1 connector, and connect video output devices to the HDMI OUT 1 and HDMI OUT 2 connectors.

The video input on the HDMI IN 1 connector is output unchanged from the HDMI OUT 1 connector. The automatic zoomed close-up image is simultaneously output from the HDMI OUT 2 connector. Connect appropriate output devices to each output.

When using the RTMP streaming function, the same video as the output on HDMI OUT 2 is streamed to a streaming service via LAN cable. When using the RTMP streaming function, set [HDMI OUT 2] as the output device for the destination in [Streaming Output 1] on the [Codec] tab (page 23).

2 Turn on the camera and peripheral devices.

Tips

- Position and configure the camera connected to the HDMI IN 1 connector beforehand so that the image captures the area to detect when a person stands or sits.
- It is recommended that the focus, white balance, and exposure of the camera connected to the HDMI IN 1 connector be set to Auto beforehand.
- A camera that supports 4K (3840×2160) output is recommended.

Configuring the Close-up by Gesture application

1 Select [Close-up by Gesture] for [Camera 1] from [Applications].

2 Click the [Setup] button.

The setup screen appears. A preview of the image from the camera connected to the HDMI IN 1 connector is displayed on the screen.

Note

If the camera image is not displayed, there may be a problem with the camera connection or settings. Check the connection and settings again.

3 Configure the following settings.

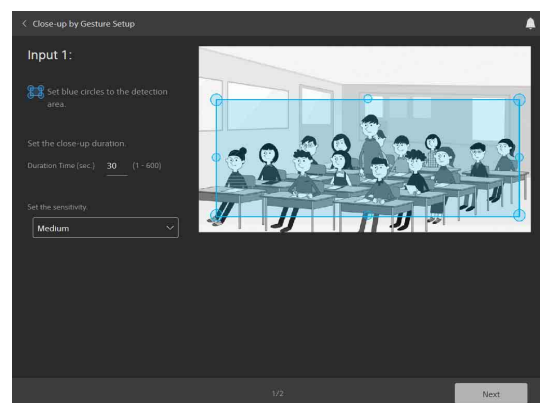

Detection area

Move the eight small and large blue circles displayed on the preview screen to mark the detection area for detecting the stand-up and sit-down triggers.

Make the detection area large enough to show the person's face when they are standing.

[Duration Time]

Set the maximum close-up duration for when the image is zoomed in response to a stand-up trigger. The zoom is automatically canceled when the close-up duration elapses, if a sit-down trigger is not detected beforehand.

Sensitivity

Select the sensitivity for detection of the stand-up and sit-down gesture trigger actions.

[Weak]: Sensitivity weaker than [Medium].

[Medium]: Standard sensitivity of the unit.

[Strong]: Respond with higher sensitivity than the [Medium] setting.

4 When finished, click the [Next] button.

5 Set the maximum and minimum sizes for detection.

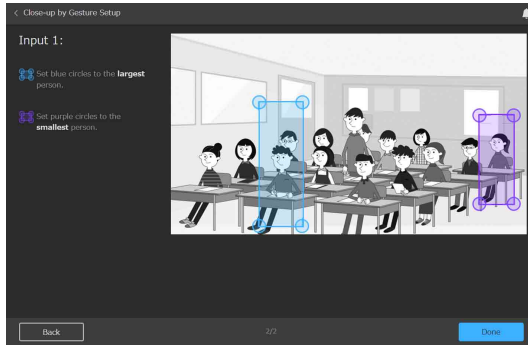

Set the maximum size and minimum size of the screen that would be fully occupied by a person when standing.

Move the four blue circles displayed on the preview screen to mark the maximum size. Move the four purple circles displayed on the preview screen to mark the minimum size.

This is used to distinguish between the difference in size that occurs between a person standing near the front and a person standing further away when viewed from the camera.

6 When finished, click the [Done] button.

The setup is saved in the unit.

Running the Close-up by Gesture application

Run this application to automatically trigger the zoom function when a person stands up and to cancel the zoom when a person sits down.

1 Select [Close-up by Gesture] for [Camera 1] from [Applications].

2 Click the [Run] button on the screen.

The run screen appears.

When zoom is active, the normal image is shown on the right and the close-up image is shown on the left.



Notes

- The close-up operation may not function correctly if the focus or exposure is not properly set for the detection area image captured by the camera.

- The close-up operation may not function correctly depending on the density of people in the detection area, the size of the person, and the attire of the person.
- The resolution of the close-up output image may be reduced depending on the resolution of the input image from the camera and the close-up zoom magnification.

Chroma key-less CG Overlay Application

This application allows you to overlay CG effects in real-time without using a dedicated studio.

This allows you to select an image or presentation content for the background of the image.

The Chroma key-less CG Overlay application can overlay up to four layers of still images or video for display.

The layers are set in the following order.

- ① **Background image layer:**
Layer for an image input from HDMI IN 2, a built-in background image, or a PNG background image uploaded into the unit.
- ② **HDMI IN 2 input layer:**
Layer for an image input from HDMI IN 2.
* Not configurable if the image input from HDMI IN 2 is used on layer ①.
- ③ **HDMI IN 1 input layer:**
Layer for an image input from HDMI IN 1.
- ④ **Foreground image layer:**
Layer for a PNG foreground image uploaded into the unit.

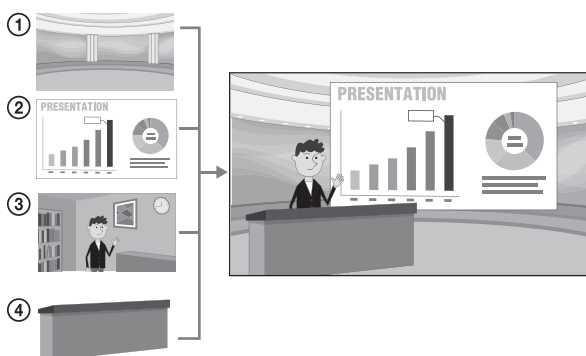

Notes

- The Chroma key-less CG Overlay option function must be enabled before configuring or running the Chroma key-less CG Overlay application. Activate the corresponding pre-installed license, or purchase and install a license.
- A crisp composite image may not always be possible, depending on the shooting environment.

Preparation before setup

Important

Adjust the focus, white balance, and exposure of the camera connected to the HDMI IN 1 connector manually.

- 1 **Check that the following preparations are in place.**

Shooting environment

During shooting, keep the lighting constant so that the shooting environment does not change, and mount the camera securely.

The image from the HDMI IN 1 connector camera is stored in the unit when the application is run (or when the [Background Refresh] button is pressed). The unit uses AI to recognize the difference between the stored image and the current image from the camera for compositing. Accordingly, the less the shooting environment changes, the more accurate the compositing can be achieved.

- * Refrain from adjusting the lighting according to the movement of the person or using a projector in the vicinity of the person.

Lighting from the front

If a shadow is created on the wall due to strong lighting from the front, there will be a difference from the background before the lighting, and the background wall may show through in the form of a shadow. When using strong lighting other than room lighting, such as tripod stand lighting, reflect the lighting off the floor or ceiling so that it does not hit the wall directly.

Clothing

Avoid wearing clothing that is the same color or similar color to the color of the background wall or other surfaces. Doing so will not achieve an appealing composite result. When shooting in a room with walls that are white or a pale color, you can obtain more detailed compositing content by wearing clothing with distinguishable colors.

- 2 **Connect a camera to the HDMI IN 1 connector, and connect a computer or video device to the HDMI IN 2 connector.**
- 3 **Connect video output devices to the HDMI OUT 1 and HDMI OUT 2 connectors.**
The composite image is output to the HDMI OUT 1 and HDMI OUT 2 connectors.
When using the RTMP streaming function, the same video as the output on HDMI OUT 1 is streamed to a streaming service via LAN cable. When using the RTMP streaming function, set [HDMI OUT 1] as the output device for the destination in [Streaming Output 1] on the [Codec] tab (page 23).
- 4 **Turn on the camera and peripheral devices.**

Note

Make sure that objects that move (such as fans, curtains, and objects visible through windows) do not come within the angle of view of the camera connected to the HDMI IN 1 connector.

Tips

- Check the position and configuration of the camera connected to the HDMI IN 1 connector beforehand so that the field of view captures the target people.
- You can also use this function when nothing is connected to the HDMI IN 2 connector.
- A composite image with left/right sides flipped can be output on the HDMI OUT 2 connector to make it easy for the user to check their movement.

Configuring the Chroma key-less CG Overlay application

1 Select [Chroma key-less CG Overlay] for [Camera 1] from [Applications].

2 Click the [Setup] button.
The setup screen appears.

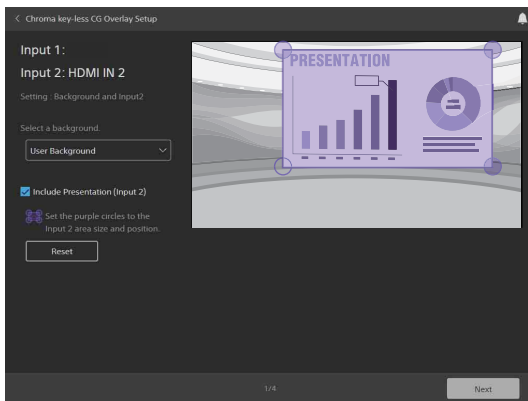

3 Select the image to use as the background from the pull-down menu.

When [HDMI IN 2] input is selected, the image that is input on the HDMI IN 2 connector becomes the background.

To use a background, upload an image file using [`<upload new background (.png)>`] in the same pull-down menu beforehand. An image file in the following format can be registered.

- File format: PNG
- File size: 50 MB or smaller
- Image size (horizontal × vertical pixels): 480×270 (min) to 3840×2160 (max)

Notes

- Only one file can be uploaded.
- When a new image file is uploaded, the existing file is overwritten.
- The uploaded file is deleted if the unit is reset to the factory defaults.
- The aspect ratio of the image is not restricted. The image data is magnified to shrunk to fit the picture size of the HDMI output.

4 To display the image that is input on the HDMI IN 2 connector in P-in-P mode, place a check mark in [Include Presentation (Input 2)].

5 Move the blue circles to change the size of the P-in-P display, and drag the blue frame to adjust the position.

Clicking the [Reset] button will return the P-in-P display to the default position and size determined for each background.

Tip

When the background is set to the HDMI IN 2 connector, the input on the HDMI IN 2 connector cannot be displayed in P-in-P mode.

6 When finished, click the [Next] button.
The following setup screen appears.

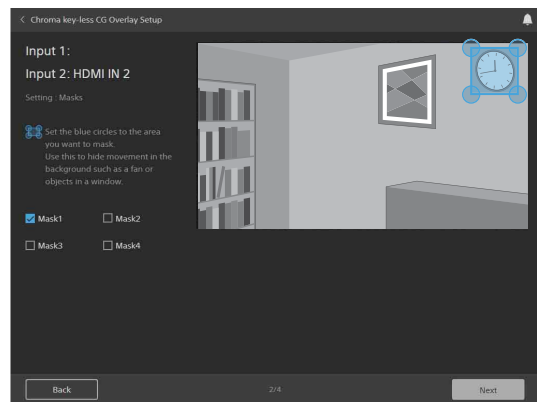

7 Adjust the angle of view of the camera connected to the HDMI IN 1 connector.

8 Place a check mark for mask items ([Mask1] to [Mask4]) you want to set, drag the displayed blue frame to position the mask, and drag the four blue circles to set the mask area.

You can set up to four mask areas.

Note

Mask the mirrors, windows, etc. that are outside the movement range of the person captured by the camera connected to the HDMI IN 1 connector if they are within the angle of view. Images of people within a mask area are not composed.

- 9** When finished, click the [Next] button.
The following setup screen appears.

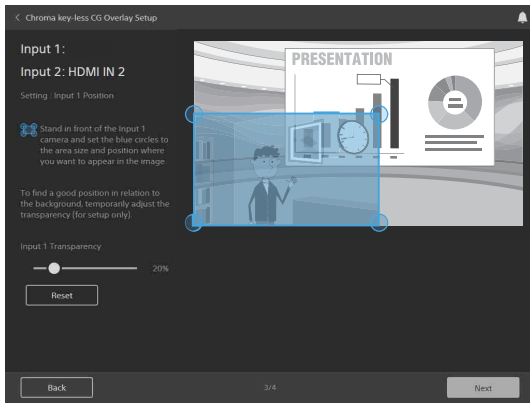

- 10** Move the blue circles to change the size of the P-in-P display, and drag the blue frame to adjust the position.
The diagram below shows an example configuration.

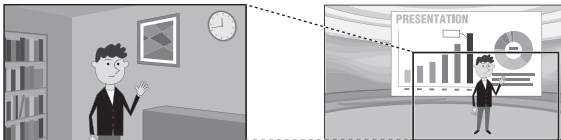

Clicking the [Reset] button will reset the P-in-P display position/size and [Input 1 Transparency] to their defaults.

- 11** Change the transparency of the image in [Input 1 Transparency].
- 12** When finished, click the [Next] button.
The following setup screen appears.

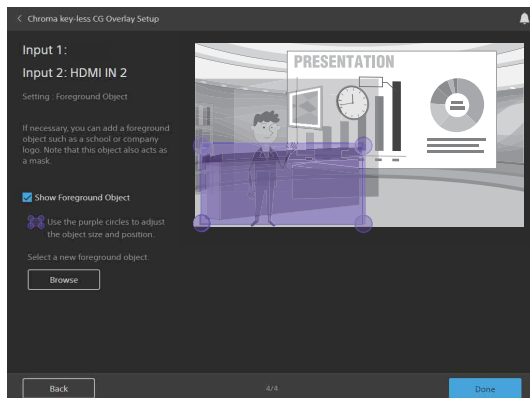

- 13** To display the foreground, place a check mark in [Show Foreground Object].
The foreground image is displayed in front of the output image.
- 14** Move the purple circles to change the display size of the foreground image, and drag the purple frame to adjust the position.
The display size changes while maintaining its aspect ratio.

Tips

- Only one foreground image can be stored on the unit. To change the foreground image, click the [Browse] button and select the image file to be registered as the foreground image on the displayed screen.
An image file in the following format can be registered.
 - File format: PNG
 - File size: 50 MB or smaller
 - Picture size (H×V pixels): 3840×2160 (max), 30×30 (min)
 Scaling in the range 16 times to 1/16 times the original image is supported.
- The foreground image is saved in the unit. To delete it, restore the factory settings (page 26).

- 15** When finished, click the [Done] button.
The setup is saved in the unit.

Running the Chroma key-less CG Overlay application

Run this application to create CG composite images without the need for a dedicated studio.

- 1** Select [Chroma key-less CG Overlay] from [Applications].
- 2** Click the [Run] button.
The run screen appears.



Note

Make sure that no people appear in the image when you click the [Run] button. Make sure that the person you want to include in the composite image only appears in the camera image after starting the application.

- 3** Perform the following operations as required.
 - [Flip Horizontally]: Flip the HDMI OUT 2 connector output and preview screen images horizontally.
 - [Show Input 1]: Display only the image that is input on the HDMI IN 1 connector on the

preview screen only. The composite image is output on the HDMI OUT 1 and HDMI OUT 2 connectors.

[Refresh Background] button: Refreshes the background information. Execute if needed when something other than the target person is extracted. When executing, make sure that no people appear in the camera image.

Real-time Cropping Application

This application simultaneously displays a wide-angle view and a cropped view, from a single camera, by cutting out a desired portion of the whole view in real-time. The focus area extraction function includes a “Focus Area Cropping” function that automatically tracks and extracts a specific object, and a “Fixed Area Cropping” function that extracts a specified area. The Focus Area Cropping function uses face recognition and face identification methods for detecting an object to be tracked. Face recognition tracks the face of an unspecified person. Face identification tracks faces registered, or temporarily registered, in the face database.

Tip

A license is not required to use the Fixed Area Cropping function, but a Focus Area Cropping license is required to use the Focus Area Cropping function.

Preparation before setup

1 Connect a camera to the HDMI IN 1 connector, and connect video output devices to the HDMI OUT 1 and HDMI OUT 2 connectors.

The video input on the HDMI IN 1 connector is output unchanged from the HDMI OUT 1 connector. The cropped image is simultaneously output from the HDMI OUT 2 connector. Connect appropriate devices to each output.

When using the RTMP streaming function, the same video as the output on HDMI OUT 2 is streamed to a streaming service via LAN cable. When using the RTMP streaming function, set [HDMI OUT 2] as the output device for the destination in [Streaming Output 1] on the [Codec] tab (page 23).

2 Turn on the camera and peripheral devices.

Tips

- Position and configure the camera connected to the HDMI IN 1 connector beforehand so that the field of view captures the area to crop.
- A camera that supports 4K (3840×2160) output is recommended.

Configuring the Real-time Cropping application

1 Select **[Real-time Cropping]** for **[Camera 1]** from **[Applications]**.

2 Click the **[Setup]** button.

The setup screen appears. A preview of the image from the camera connected to the HDMI IN 1 connector is displayed on the screen.

Note

If the camera image is not displayed, there may be a problem with the camera connection or settings. Check the connection and settings again.

3 Configure the following settings.

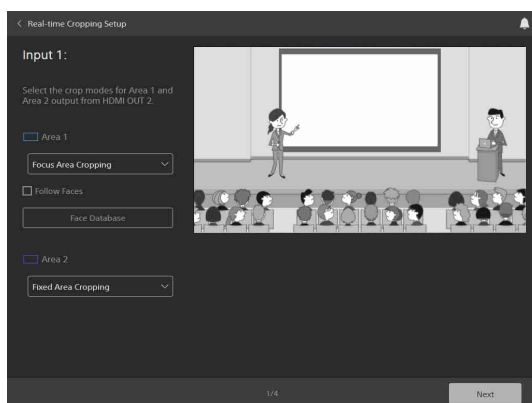

[Area 1]

Select the crop processing mode for area 1 ([Fixed Area Cropping] or [Focus Area Cropping]).

Follow Faces

Enabled when area 1 is set to [Focus Area Cropping]. Insert a check mark to use the face identification tracking function. The face identification function tracks the faces of identified registered persons. This function can also be used to track a specific face when there are more than one person on the screen.

Face Database

Enabled when a check mark is placed in [Follow Faces]. Click the button to display the face registration screen. For details about operation on the face registration screen, see “Registering a face in the face database” (page 49).

[Area 2]

Select the crop processing mode for area 2 ([Fixed Area Cropping] or [Focus Area Cropping]). Only [Fixed Area Cropping] can be selected when a check mark is placed in [Follow Faces].

Note

A Focus Area Cropping license is required to use the Focus Area Cropping function.

4 When finished, click the **[Next]** button.

5 Configure the **[Area 1]** and **[Area 2]** settings.

If the crop functions selected in [Area 1] and [Area 2] are the same, the settings for one area are applied to both areas. If they are different, configure the settings separately.

[Area 1] is indicated by a blue frame and corner circles.

[Area 2] is indicated by a purple frame and corner circles.

When the crop processing mode is [Fixed Area Cropping]

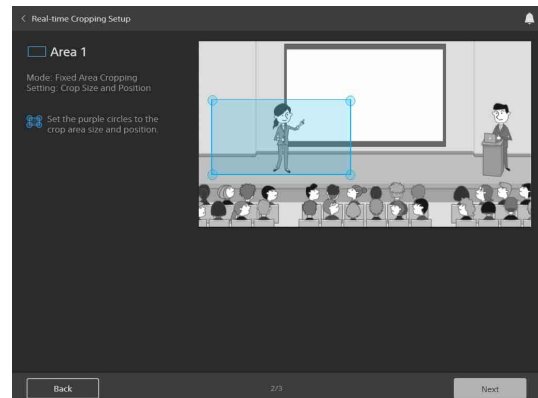

Crop area position

Move the blue frame or purple frame displayed on the preview screen to specify the crop position.

Crop area size

Move the four blue circles or purple circles displayed on the preview screen to specify the size of the crop area.

When the crop processing mode for area 2 is [Focus Area Cropping], click the [Next] button and configure the settings described below.

When the crop processing mode is [Focus Area Cropping]

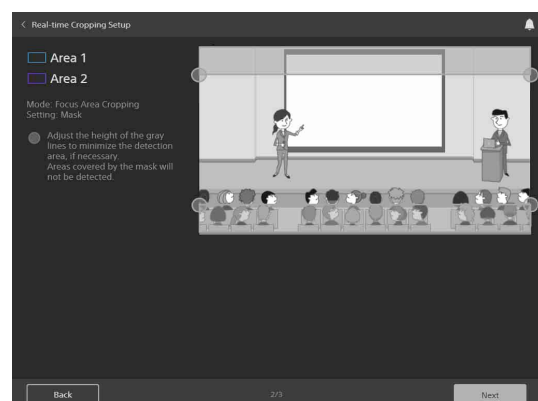

Mask

Set the mask areas in order to prevent false detection of objects other than the person to be tracked during tracking.

Move the four gray circles displayed on the preview screen, as required, to adjust the height to effectively narrow the detection area during tracking.

The mask areas are excluded from the detection target during tracking.

6 When finished, click the [Next] button.

The following setup screen appears.

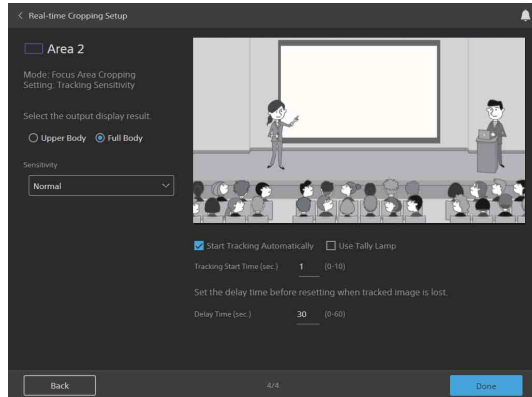

Note

The [Size of the tracked object], [Sensitivity], and [Delay Time] parameters are reflected in both tracking by face recognition and tracking by face identification.

The [Start Tracking Automatically] and [Tracking Start Time] parameters are used only for tracking by face recognition. They are not used for tracking by face identification.

Tracking object size

Select the size of the object to keep tracked within the image during tracking.

[Upper Body]: Keep the upper half of the person to be tracked within the image.

[Full Body]: Keep the full body of the person to be tracked within the image.

Sensitivity

Set the response sensitivity for tracking when the person to track starts to move.

[Normal]: Respond with standard sensitivity.

[Sensitive]: Respond with higher sensitivity than the [Normal] setting.

Start tracking automatically

Place a check mark in [Start Tracking Automatically] to automatically start tracking when a person to be tracked is detected. Leave the checkbox empty when you want to start tracking manually.

Also, always set [Tracking Start Time (sec.)] for automatic tracking.

Tracking start time

Automatic tracking starts when a person has been captured continuously for a duration exceeding the time set in [Tracking Start Time (sec.)].

Delay Time

Set the wait time from when the person being tracked is no longer visible until tracking is deemed to be lost.

Tracking tally lamp

Enabled when a camera equipped with a tally lamp is connected. Insert a check mark to turn on the tally lamp of the tracking camera.

For details about cameras that support this function, see “Supported Cameras and Available Camera Functions” (page 54).

7 When finished configuring areas 1 and 2, click the [Done] button.

The setup is saved in the unit.

Running the Real-time Cropping application

Run this application to simulate the output of two cameras by showing a main image and a cropped image.

Note

If a face is partially obscured, due to wearing a mask or other reason, appropriate tracking may not be possible.

1 Select [Real-time Cropping] for [Camera 1] from [Applications].

2 Click the [Run] button.

The run screen appears.

The normal image is shown on the right and the cropped image is shown on the left.

Note

When [Auto] is selected, the face identification function searches the face database for data in order of priority, and then tracks the first matching face. If a face with higher priority subsequently becomes visible, the tracking target does not change. To start tracking the person with a face that has higher priority, click the [Reset] button. The function again searches for targets in order of priority for tracking. If no person is found that matches the registered face data, the search continues using face identification. Also, if sight of the face of the person being tracked is lost and the time set in [Delay Time] has elapsed since tracking was lost, the search will be performed again in order of priority and tracking resumes.

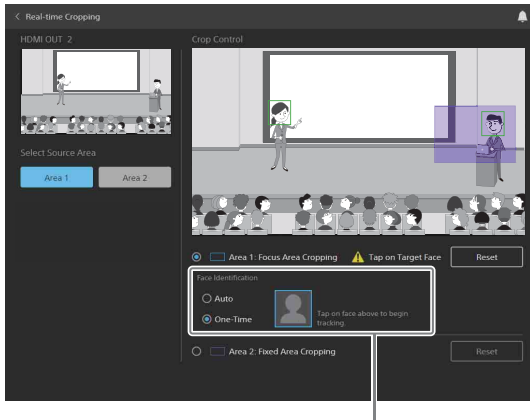

Display when face identification function is enabled

[Select Source Area]

Select the area to display on HDMI OUT 2. [Area 1] is selected by default when the application is launched.

[Crop Control]

Use to control cropping.

[Area 1: Focus Area Cropping], [Area 2: Fixed Area Cropping]: Select the target area to control.

[Reset] button: Click the [Reset] button to restore the extraction area to the initial position. When [Focus Area Cropping] is selected, tracking is interrupted and detection of a person to track starts again. Also, if [One-Time] is selected for the face identification tracking function, the identification of the face that is selected or being tracked is cleared.

Face Identification

Select the method for identifying faces. Displayed when a check mark is placed in [Follow Faces] on the setup screen.

[Auto]: Search for tracking target from faces registered in the face database.

[One-Time]: Search for faces within the current camera image, and display a frame around detected faces. Click a frame to start tracking that face. The face data registered in the face database is not used.

When the target control area is set to [Fixed Area Cropping]

Drag the blue frame or purple frame to move the crop area position.

When the target control area is set to [Focus Area Cropping]

Enable [Start Tracking Automatically] to track a person captured by the camera, according to the setup, and to output the tracking image. You can check the operating status of the application in the bottom right of the screen while the application is running.

[Detecting]: Person is detected at the home position. A face frame is attached to the person.

[Tap on Target Face]: In this state, you can select the face frame of a person to be tracked manually. Select a face frame.

[Tracking]: Person was detected and is being tracked.

[Target Lost]: Person being tracked is no longer visible and tracking has been lost.

To start tracking manually

If using the face identification tracking function:

Select [One-Time] and click the frame of a detected face while the application is in [Tap on Target Face] state to select that face as the tracking target and start tracking.

If [Start Tracking Automatically] is disabled and the face identification tracking function is not being used:

Select [One-Time] and click the frame of a detected face while the application is in [Tap on Target Face] state to select that face as the tracking target and start tracking.

If [Start Tracking Automatically] is enabled and the face identification tracking function is not being used:

Click the frame of a detected face while the application is in [Detecting] state to select that face as the tracking target and start tracking.

Notes

- If the source area is changed while the application is running, the changes are not saved in the settings.
- You can change the crop area position while the application is running, but the changes are not saved in the settings.
- The resolution of the close-up output image may be reduced depending on the resolution of the input image from the camera.

Registering a face in the face database

Register the faces of people to use with the face identification function. Click [Face Database] (page 47) on the setup screen to display the face registration screen. Up to 100 faces can be registered.



Note

All face data registered in the face database are deleted when the unit is reset to factory defaults.

[Capture]

Click the [Capture] button when person whose face you want to register is facing the front. The screen display becomes a still image display, and frames are displayed on the detected faces. Click the frame for the person you want to register.

Note

Only register a face when the person is facing the front. Faces not facing the front cannot be identified.

[Redo]

Click the button to perform the capture operation again.

[Name]

Enter the name of the person to register. Enabled when the unit is ready to register the face.

[Register]

Register the face data in the face database. The [Register] button is enabled when the unit is ready to register the face.

Note

Not enabled if the maximum number of registered faces has been reached.

[Registered Faces]

Displays the faces registered in the face database. The number at the top left of each face image is the detection priority. When registered faces appear simultaneously on the screen, the person with the highest priority is tracked.

[Edit]

Click to open the edit screen for the face database.

Editing the face database

On the edit screen, you can change the name, change the priority, and delete face data.

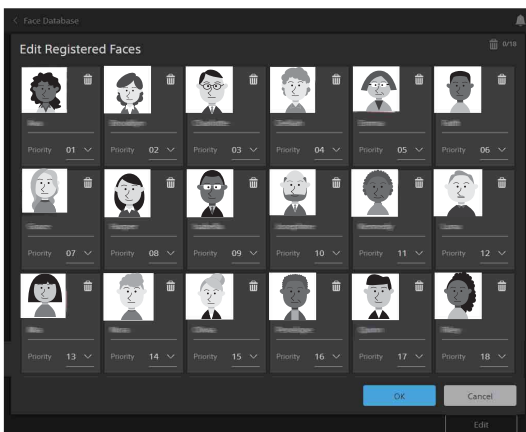

Registered faces are displayed in thumbnail view. The face data displayed for each person comprises a face picture, trash icon, name, and priority number.

Face picture

Picture of the face of the registered person.

Trash icon

Click the trash icon, turning it blue, to select that face for deletion. All faces showing a blue trash icon are deleted when the [OK] button at the bottom right of the screen is clicked. Multiple face data can be marked for deletion.

Note

Deletion of face data cannot be undone. If a face is deleted by error, register the face again.

[Name]

Edit the name. Changes are applied when the [OK] button at the bottom right of the screen is clicked.

[Priority]

You can edit the [Priority] level. The displayed faces are sorted by priority starting from 1. Changes are applied when the [OK] button at the bottom right of the screen is clicked.

[OK] button, [Cancel] button

Click the corresponding button to apply changes or cancel changes to the face database. After clicking, the display returns to the face registration screen.

Message List

The following messages may appear on the unit. Perform the following as necessary.

LED indicators

LED	Meaning and solution
STATUS LED is red	The unit is not connected to the network. Check the network cable connection.
STATUS LED is flashing red	A problem, such as high temperature, occurred in the unit. Turn off the unit and allow it to cool before turning the unit on again.
POWER LED is green and STATUS LED is off	If this state occurs after the unit is powered on, the unit did not start up correctly. Disconnect the AC adapter, and then reconnect it to turn the unit on.

Web browser display

Message	Meaning and solution
The device's temperature is high. Shut down the device and wait until it has cooled off before proceeding.	Power off the unit and wait until it has cooled down. Check that the temperature has decreased before connecting the power again to start the unit.
No HDMI Input Signal There is no HDMI input signal. Correctly connect a device with an HDMI signal.	There may not be an input device connected correctly to the HDMI IN connector. Check the input device and its connection, then turn the unit off and then on again.
Incorrect HDMI Input The HDMI input signal format is incorrect. Switch the HDMI input signal.	The HDMI input signal may not be in a format supported on the unit. Check the input signal.
Copyrighted Input Cannot display copyrighted signals (HDCP). Change the input signal.	An input signal protected using HDCP may have been input on HDMI IN. Check that the input signal is not protected using HDCP.
License Will Expire The license will expire soon. Please renew the license.	The license for the currently active option function will expire soon. To continue using the option function, purchase and activate a license.
The license for operating the application is invalid. Please validate the license.	An option function license required for the application has not been installed. Activate a pre-installed license, or purchase and install a license.
The software update has failed. Check the software version.	Check that the software update was completed successfully or check the software version.
Connected camera is not compatible. Correctly set the camera's IP address and model name in the Input/Output settings and connect a compatible camera.	An application may not function because a camera that is not compatible is connected to the unit. Check the camera. Also, check that the camera to be connected is configured correctly in "Input/Output" (page 14).
A compatible interconnecting camera is not connected.	The camera may not be connected properly using a network cable or the camera may be turned off. Check the connection status and power source. Also, check that the camera to be connected is configured correctly in "Input/Output" (page 14).
The composition cannot be adjusted because tracking is not in progress. Adjust the composition after tracking resumes.	Wait until tracking resumes or return to the home position to resume.
Foreground data is broken. Please upload again.	The foreground data saved on the unit is corrupted. Upload the data again from the Chroma key-less CG Overlay setup screen.

Message	Meaning and solution
The size of the foreground data is not compatible. Please change the size and upload again.	The data size or number of pixels of the uploaded foreground data is too small or too large. Change the data size and then upload again.
The format of the foreground data is not compatible. Please use .png format data for the foreground.	Upload foreground data again that is in a compatible format. For details about the foreground data format, see (page 45).
Unable to connect to the streaming destination server. Set the correct connection destination information in the streaming settings.	Could not connect to the RTMP streaming upload destination. Check the server URL setting.
Unable to connect to the streaming destination server. Set the correct connection destination information and certificate in the streaming settings.	Could not connect to the RTMP streaming upload destination. Check the server URL, stream key, and certificate.
Streaming to the following URL was disconnected due to an error.	The connection to the RTMP streaming upload destination was disconnected. Check the network connection with the upload destination.
One of the two applications cannot be executed because it is not set or the license is invalid. To run the two at the same time, activate the license and configure the settings on the application settings screen.	While configured to run two applications at the same time, one of the applications has not been configured or the license valid period has expired. If you have a license, you can run the two applications by configuring the application that has not yet been configured. If the license valid period has expired, purchase a license. Or use the application that does have a license alone.

Troubleshooting

Before requesting service, check the following as a guide to troubleshooting the problem. If the problem persists, consult your Sony dealer.

Symptom	Cause	Solution
The unit does not turn on.	The AC adapter is not firmly connected to the power connector.	Insert the power cord firmly as far as it will go.
	The power cord is not firmly connected to the AC adapter or the power outlet.	Insert the power cord firmly as far as it will go.
There is no picture on monitor or external device connected to the HDMI output.	The HDMI cable is not connected correctly.	Check the input, external device, and their connection.
	The HDMI output video format is not set correctly.	Check the output video format of the unit and the input video format of the external device.
	The camera or other device connected to the HDMI input may not be turned on.	Check the power source of the camera or other connected device.
	The output video format of the camera or other device connected to the HDMI input is not set correctly.	Check the output video format of the camera or other device.
An application will not run.	The option function required for the application is not enabled.	Purchase and install a license or activate a pre-installed license to enable the option function.
Cannot install a license.	The correct license file for the target device is not installed.	The Unique Device ID used when the license file was issued may not have been specified correctly. Check the Unique Device ID on the [License] screen.
Cannot connect to the network.	–	Check that the network cables are connected correctly to the unit, router, and computer.
	–	Enable DHCP on your router.
	–	A network cable may be damaged. Replace damaged cables.
SRG-300SE/301SE/201SE is connected but the model name of the camera is not displayed.	The VISCA interface setting on the SRG-300SE/301SE/201SE is not set to [IP].	Access the SRG-300SE/301SE/201SE from a web browser, and set [VISCA Interface] on the [Network] tab to [IP].
The problem persists after trying all solutions.	–	Disconnect the power cord plug from the AC outlet, then reinsert it into the AC outlet after waiting a while.

Supported Cameras and Available Camera Functions

○: Supported, -: Not supported

Model name	Pan, tilt, zoom	Exposure, white balance	Tally lamp
BRC-X1000	○	○	○
BRC-H800	○	○	○
BRC-H780	○	○	○
BRC-X400	○	○	○
BRC-X401	○	○	○
SRG-X400	○	○	-
SRG-201M2	○	○	-
SRG-X402	○	○	-
SRG-X120	○	○	-
SRG-HD1M2	○	○	-
SRG-360SHE	○	○	○
SRG-280SHE	○	○	○
SRG-300SE	○	○	-
SRG-301SE	○	○	-
SRG-201SE	-	○	-
SRG-300H	○	○	-
SRG-301H	○	○	-
SRG-120DH	○	○	-
SRG-121DH	○	○	-
SRG-120DS	-	○	-
SRG-HD1	-	○	-
SRG-XB25	-	○ (V1.2 and later)	○
SRG-XP1	-	○ (V1.2 and later)	○

Notes

- Use these settings as the defaults on remote cameras that can set the pan/tilt speed type and zoom speed type.
- Use these settings as-is on remote cameras that can set PAN REVERSE/TILT REVERSE.
- On cameras with a tally lamp that have a tally mode setting function, you can configure the tally mode settings so that the tally lamp does not turn on. When the tally lamp is configured not to turn on, the tally lamp will not turn on when the camera receives a tally on command from the unit. To use the tally lamp on function during tracking, configure the tally mode settings so that the tally lamp turns on.

About Use of GNU GPL/ LGPL Software

This product uses software to which the GNU General Public License (GPL) or GNU Lesser General Public License (LGPL) applies. This informs you that you have a right to have access to, modify, and redistribute source code for these software programs under the conditions of the GPL/LGPL.

The source code is provided on the internet. Use the following URL and follow the download instructions.
<http://oss.sony.net/Products/Linux>

We would prefer that you do not contact us about the contents of the source code.

Specifications

Video input signal

HDMI IN 1 connector

3840×2160/29.97p

1920×1080/59.94p

3840×2160/25p

1920×1080/50p

HDMI IN 2 connector

1920×1080/59.94p

1920×1080/50p

Video output signal

HDMI OUT 1 connector

3840×2160/29.97p

1920×1080/59.94p

3840×2160/25p

1920×1080/50p

HDMI OUT 2 connector

1920×1080/59.94p

1920×1080/50p

Audio input signal

HDMI IN 1 connector / HDMI IN 2 connector

LCPM, 16-bit, 2ch stereo

48 kHz/44.1 kHz/32 kHz

MIC IN connector

Audio conversion to LPCM, 16-bit,
2ch stereo, 48 kHz

Audio output signal

HDMI IN 1 connector / HDMI IN 2 connector

LCPM, 16-bit, 2ch stereo,

48 kHz/ 44.1 kHz/32 kHz

Input/output connectors

HDMI IN 1 / HDMI IN 2 connectors

HDMI connector (Type A) (2)

HDMI OUT 1 / HDMI OUT 2 connectors

HDMI connector (Type A) (2)

MIC IN connector

Stereo, ø3.5 mm mini jack,
plug in power 5 V (1)

LAN connector

RJ-45 (1000BASE-T/100BASE-TX/
10BASE-T)

Power connector

IEC 60130-10 Type A
(5.5 mm outer diameter, 2.5 mm
inner diameter)

General

Input voltage	12 V DC (Use an AC adapter (not supplied))
Power consumption	40 W with 12 V DC input
Operating temperature	5 °C to 40 °C (41 °F to 104 °F)
Storage temperature	-20 °C to +55 °C (-4 °F to +131 °F)

External dimensions

See “External dimensions” (page 56).
Mass Approx. 860 g (1 lb 14 oz)

Design and specifications are subject to change without notice.

External dimensions

